

**TECHNICAL MANUAL
OPERATOR, UNIT, DIRECT SUPPORT
AND GENERAL SUPPORT
MAINTENANCE MANUAL
(INCLUDING REPAIR PARTS AND
SPECIAL TOOLS LIST)**

FOR

**WATER PURIFICATION BARGES
(NSN 1930-01-234-2165)
VOLUME 10
LIGHTING SYSTEM**

This technical manual is an authentication of the manufacturer's commercial literature and does not conform with the format and content requirements normally associated with the Army technical manuals. This technical manual does, however, contain all essential information required to operate and maintain the equipment.

Approved for public release; distribution is unlimited.

*This manual supersedes TM 55-1930-209-14&P-10, 30 January 1989.

**H E A D Q U A R T E R S , D E P A R T M E N T O F T H E A R M Y
15 OCTOBER 1992**

WARNINGS AND SAFETY NOTICES

WARNING

**DANGEROUS VOLTAGES AND HAZARDOUS MATERIALS
ARE USED IN THIS EQUIPMENT.
DO NOT TAKE CHANCES!**

GENERAL WARNINGS

- Always redtag electrical equipment, controls, circuits, and switches before beginning repairs.
- Do not service or adjust high voltage electrical equipment when alone.
- Do not overload circuits.
- Always use authorized, insulated tools and test equipment when working on electrical equipment.
- Remove all jewelry before working on or around electrical equipment with exposed current-carrying areas.
- Do not wear clothing with exposed metal fasteners when working on electrical equipment.
- Always use approved breathing apparatus when working with chemicals.
- Avoid chemical contact with eyes, skin, and clothing.
- Always wear safety glasses, gloves, and rubber aprons when handling chemicals.
- Wear protective clothing and safety glasses as required when working on barge equipment.
- Always wear approved ear protection in noise hazard areas.

SPECIFIC WARNINGS

- Do not connect any new circuit to an existing circuit.
- Do not energize circuits if water condensation is present.
- If any sparks are seen, stop operation immediately. Determine cause and take corrective action.
- Never touch radio antennas of fixed-base radio transmitters. When transmitting, antennas contain high voltage.
- Always use approved breathing apparatus when handling material in multimedia filters and chlorination unit descaling acid crystals. Do not breathe dust from these materials.
- Avoid breathing vapors from coagulant aid chemicals. Use in a well-ventilated area. In case of chemical contact with skin, wash with water. For eyes, immediately flush at eyewash station and obtain medical help as soon as possible.
- Always wear work gloves and shirts with full length buttoned sleeves when handling fuel oil and gasoline.

- Do not smoke or have open flames within 10 feet when handling fuel oil or gas. Only minimum number of personnel necessary to conduct fueling operation is permitted in area.
- Before starting any repairs on compressed air system, always release pressure from air receiver and compressor and open and re-tag circuit breakers.
- On air compressor, do not adjust automatic regulator switch (pressure switch) and pilot valve settings.
- To avoid flying particles lodging in eyes, do not use compressed air to "dust-off" clothing or workspace.
- Stay clear of anchor cables when operating anchor winches.
- Always wear safety glasses or face shield when using power tools.
- Always wear lifevests when on weatherdeck and throughout the barge during storm conditions.
- Lifevests are to be worn at all times aboard workboat.

- Only qualified persons will operate and maintain arc and fuel gas welders.
- When welding, always make sure those working with or near the welder wear proper clothing: heavy, hole-free gloves, heavy shirt, cuffless trousers, high shoes, and cap. Keep clothing dry and free of oil and other flammable substances.
- Use dry heavy canvas drop cloth to cover work area and adjacent deck when arc welding.
- Before welding on bulkheads, deck plating and similar surfaces, always check carefully to make sure that the other side of the surface to be welded does not hide fuel or compressed gas tanks, flammable or hazardous materials, or electrical equipment or wiring.
- When welding, keep your head out of the fumes and make sure area is well ventilated.
- Before welding on surfaces which have been cleaned with cleaning solutions containing chlorinated hydrocarbons, always wash with water, dry and ventilate area thoroughly.
- Use shield with proper filter lens when welding. Do not allow others near welding operations to assist or observe without proper eye protection. This must include side shields during slag chipping operations.
- Warn personnel in area during welding operations not to look at arc or expose themselves to hot spatter or metal.
- In an extreme emergency, when welding is required in void 2 port, shut down chlorination system. Close all valves. Cover the parts of chlorination system not being welded with a heavy canvas drop cloth. Turn on vent 8 and, if available, provide additional forced air ventilation.

b

- Before welding on fuel oil or sludge tank, make sure tank is gas-free by: 1) removing all liquid from tank, 2) cleaning tank thoroughly, 3) seeing that tank is thoroughly dry, and 4) force ventilating tank.
- Connect arc welding work cable as close to welding area as possible. Work cables connected to barge framework or other locations far from welding site increase the possibility of the welding current passing through lifting chains, crane cables or other possible circuit paths. This can create fire hazards or weaken lifting chains or crane cables until they break or fall.
- Always weld with all doors, portholes, and hatches propped open and necessary ventilation systems operating.
- Take frequent breaks away from the area where you are welding.
- Do not take oxygen and acetylene tanks into confined areas when welding.
- Always use a friction lighter to start oxyacetylene torch.
- Always maintain all welding equipment in proper working condition. If you have any doubts about the safety of any welding equipment, do not use the welder.

ELECTRICAL SHOCK SAFETY STEPS

Five safety steps to follow if someone is the victim of electrical shock.

1. Do not try to pull or grab individual.
2. Turn off electrical power when possible.
3. If you can not turn off electrical power, pull, push, or lift person to safety using a wooden pole, rope, or some other insulating material.
4. Get medical help as soon as possible.
5. After the injured person is free of contact with the source of electrical shock, move the person a short distance away and, if needed, start CPR immediately.

c/(d blank)

INTRODUCTION TO**TM 55-1930-209-14&P-10**

You can help improve this manual. If you find any mistakes or if you know of a way to improve the procedures, please let us know. Mail your letter, DA Form 2028 (Recommended Changes to Publications and Blank Forms), or DA Form 2028-2 located in the back of this manual direct to: Commander, US Army Troop Support Command, ATTN: AMSTR-MMTS, 4300 Goodfellow Blvd., St. Louis, MO 63120-1798. A reply will be furnished directly to you.

1. SCOPE

TM 55-1930-209-14&P covers the Reverse Osmosis Water Purification Barges, Models 300-WPB-1, 300-WPB-2 and 300WPB-3, NSN 1930-01-234-2165. This manual consists of twenty-one volumes.

2. REVERSE OSMOSIS WATER PURIFICATION BARGES

The Reverse Osmosis Water Purification Barges provide up to 300, 000 gallons of drinking water per 24 hour period. The drinking water, converted from seawater or brackish water, is for use by a Rapid Deployment Force in a forward area. When needed, the drinking water can be pumped to a shore facility or to another vessel. This manual provides operation and maintenance procedures for all the component systems on the barges.

3. VOLUME 1 -- NORMAL OPERATIONS

This volume provides information and procedures on normal Reverse Osmosis Water Purification Barge operations, including barge movement and deployment, communications and electrical power systems, drinking water production, shutdown, and required operational maintenance. Emergency shutdown procedures are also provided.

4. VOLUME 2 -- SEAWATER SYSTEM

This volume describes operation and maintenance of the seawater system which supplies seawater to the Reverse Osmosis Water Purification Units (ROWPUs) for processing to the air conditioning unit for cooling to the ballast tank for barge trimming to the chlorination unit for priming and cooling, and to the diesel generators for cooling.

5. VOLUME 3 -- REVERSE OSMOSIS WATER PURIFICATION UNIT (ROWPU) SYSTEM

Volume 3 provides operation and maintenance procedures for the ROWPU System which processes seawater or brackish water to produce drinking water. Normally, this system processes seawater supplied by the seawater system (TM 55-1930-209-14&P-2) to create product water. Chlorine is then added to this product water by the chlorination system (TM 55-1930-209-1 4&P-4). The resultant drinking water is discharged into four storage tanks that are part of the drinking water system (TM 55-1930-209-1 4&P-5).

6. VOLUME 4 -- CHLORINATION SYSTEM

Operation and maintenance procedures for the chlorination system onboard the Water Purification Barges are contained in this volume. This system produces chlorine in a sodium hypochlorite solution, upon demand, to water processed by the ROWPU system just before the water enters the four drinking water storage tanks.

7. VOLUME 5 -DRINKING WATER SYSTEM

The drinking water system provides storage for water produced by the ROWPUs and includes pumps and valves to move this water from onboard storage tanks to the shore discharge system, to another vessel, or overboard. The drinking water system also provides a pressurized water supply for drinking and washing onboard the barges.

8. VOLUME 6 -SHORE DISCHARGE SYSTEM

This volume provides operation and maintenance procedures for the shore discharge system which transfers drinking water from barge storage tanks to holding/storage facilities ashore.

9. VOLUME 7 -COMPRESSED AIR SYSTEM

Volume 7 describes the operation and maintenance of the compressed air system which provides compressed air to five air stations in the ROWPU space, one in the workshop, and one on stem weatherdeck. This system also provides compressed air to two air stations for blowdown of sea chests in void 2 starboard and void 4 port. Compressed air is used on the barges to operate air-powered impact tools, to propel air through the shore discharge hose, to blowdown sea chest, and for general cleaning blowdown.

10. VOLUME 8 -FUEL OIL SYSTEM

This volume provides operation and maintenance procedures for the fuel oil system which functions as a centralized receiving storage and distribution system for diesel fuel used for barge operations. This onboard fuel system provides fuel for two 155 kW diesel ship service generators, a 20 kW ship auxiliary generator, two ROWPU high-pressure pump diesel engines, and a fueling station for the barge workboat.

11. VOLUME 9 -ELECTRICAL POWER SYSTEMS

Operation and maintenance procedures for the two electrical power systems installed aboard the Water Purification Barges are contained in Volume 9. The normal electrical power system generates, controls and distributes all electrical power for operating the water purification system and its auxiliary systems. The emergency electrical system supplies 24 Vdc from a battery bank to 24 Vdc equipment and converts to 24 Vdc through an inverter to 120 Vac to power emergency lighting and equipment.

12. VOLUME 10 -LIGHTING SYSTEM

Volume 10 contains operation and maintenance procedures for the onboard lighting systems for the Water Purification Barges. This system supplies interior and exterior lighting. Normal and emergency interior lighting is provided in the deckhouse ROWPU space, dayroom, workshop, and voids. Exterior lighting consists of searchlights and floodlights for use at night or during reduced visibility. Lights on the weatherdecks and standard navigation and status lights are for use during operation and towing.

13. VOLUME 11 -EQUIPMENT MONITORING SYSTEM

This volume provides operation and maintenance procedures for the equipment monitoring system which monitors the operation of several equipment components onboard the Water Purification Barges. This system monitors operating conditions such as amount of drinking water in storage tanks and temperature of diesel engine cooling water. Sensors detect unacceptable operating conditions, the main processor flashes at double intensity and remote alarms (horns, strobe lights and buzzer alert crewmembers that corrective action is necessary.

14. **VOLUME 12 -COMMUNICATIONS SYSTEM** Operation and maintenance procedures for the communications system are provided in Volume 12. This system consists of three separate communications methods, radio communications, foghorn and intercom telephones.
15. **VOLUME 13-HANDLING EQUIPMENT** This volume contains operation and maintenance procedures for handling equipment used for lifting, transporting and repositioning equipment and materials onboard the barges. The system includes a bridge crane, bow crane and a void 4 trolley hoist.
16. **VOLUME 14 -ANCHOR, MOORING, AND TOWING EQUIPMENT** Volume 14 describes the operation and maintenance procedures for the anchor mooring, and towing equipment on the Water Purification Barges. This equipment provides a method to hold (anchor) the barges in a fixed position offshore, at dockside, or next to another vessel and a method to move the barges from one location to another.
17. **VOLUME 15 -MISCELLANEOUS EQUIPMENT (DAYROOM, WORKSHOP, ACCESSES, AND SANITATION SYSTEMS)** Volume 15 addresses operation and maintenance procedures for miscellaneous equipment installed on the Water Purification Barges. This equipment includes the dayroom on the forward starboard side of deckhouse, the workshop on the forward portside of deckhouse, accesses such as deckhouse doors and portholes and various accesses to and from the voids, and two separate sanitation systems (toilets and bilge). Additional equipment addressed in this volume includes: guard rails, rubber fendering, removable rubber floor mats, eyewash stations, component labels, caution, warning and danger signs, and storage: areas.
18. **VOLUME 16 -VENTILATION, HEATING, AND AIR CONDITIONING SYSTEMS** This volume contains operation and maintenance procedures for the deckhouse and voids ventilation systems and the heating and air conditioning (HAC) system installed on the Water Purification Barges. The ventilation system provides fresh air circulation in the deckhouse and voids with 17 hatches and 10 ventilation fans. The HAC controls the temperature in the dayroom and deckhouse.
19. **VOLUME 17 -WORKBOAT, LIFESAVING, AND FIREFIGHTING EQUIPMENT** Volume 17 includes procedures for the operation and maintenance of:
 - a. Workboat -provides water transportation for crew members and visitors, small cargo items, transportation of the messenger line for the shore discharge hose and similar work-related tasks associated with operating the Water Purification Barges.
 - b. Lifesaving Equipment -installed on the barges and consisting of 2 life rafts, 15 Type II and 24 Type V lifevests and 4 lifesaving rings.
 - c. Firefighting Equipment -installed on the barges and consisting of Halon 1301 system, 2 CO2 hose reel units, a smoke detector system, 17 portable CO2 fire extinguishers, 5 dry chemical fire extinguishers, 5 self-contained breathing apparatuses, and a portable, engine driven fire fighting pump. The workboat also has a 10-pound, portable, dry chemical fire extinguisher.
20. **VOLUME 18 -SUPPORTING APPENDICES FOR VOLUMES 1-17.**

Volume 18 contains the Maintenance Allocation Chart, Components of End Item List, Tools and Test Equipment List, Expendable/Durable Supplies and Materials List and the Repair Parts and Special

All of the information contained in this volume is common to volumes 1-17 and does not appear in each individual volume.

Appendix A in volumes 1-17 provides information unique to each volume. Appendix B in volumes 1-17 provides manufacturers manuals and instructions unique to the system described in each volume. Appendixes C-G are located in Volume 18.

21. VOLUME 19 -PREVENTIVE MAINTENANCE CHECKS AND SERVICES (PMCS)

Volume 19 contains PMCS pertinent to all onboard systems for the Reverse Osmosis Water Purification Barges.

22. VOLUME 20 -SUPPLEMENTAL DATA

Volume 20 contains the Basic Issue Items List, and additional Authorization List for all onboard systems for the Reverse Osmosis Water Purification Barges.

23. VOLUME 21 -WINCH, DOUBLE DRUM, DIESEL

This volume contains operation and maintenance procedures for the 20-ton double drum diesel engine winch used on the Water Purification Barges. Appendix B of Volume 21 contains the Maintenance Allocation Chart and the Repair Parts and Special Tools List for the winch.

TECHNICAL MANUAL
NO. 55-1930-209-14&P-10

HEADQUARTERS
DEPARTMENT OF THE ARMY,
WASHINGTON D.C., 15 OCTOBER 1992

TECHNICAL MANUAL

OPERATORS', UNIT, DIRECT SUPPORT
AND GENERAL SUPPORT
MAINTENANCE MANUAL
(INCLUDING REPAIR PARTS AND
SPECIAL TOOLS LIST)

FOR
WATER PURIFICATION BARGES
(NSN 1930-01-234-2165)
VOLUME 10
LIGHTING SYSTEM

REPORTING ERRORS AND RECOMMENDING IMPROVEMENTS'

You can help improve this manual. If you find any mistakes or if you know of a way to improve the procedures, please let us know. Mail your letter, DA Form 2028 (Recommended Changes to Publications and Blank Forms), or DA Form 2028-2 located in the back of this manual direct to: Commander, US Army Troop Support Command, ATTN: AMSTR-MMTS, 4300 Goodfellow Blvd., St. Louis, MO 63120-1798. A reply will be furnished directly to you.

Approved for public release; distribution is unlimited.

* Supersedes TM 55-1930-209-14&P-10, 30 January 1989

A/(B blank)

TABLE OF CONTENTS

VOLUME 10

		<u>Page</u>
CHAPTER 1	INTRODUCTION.....	1-1
Section I.	General	1-1
1-1	Purpose	1-1
1-2	Scope	1-1
1-3	Warranties and guarantees	1-1
1-4	Maintenance forms and records.....	1-1
1-5	Destruction of Army materiel to prevent enemy use	1-1
1-6	Storage	1-1
CHAPTER 2	INTERIOR LIGHTING SYSTEM	2-1
Section I.	Description and data	2-1
2-1	Description	2-1
2-2	Equipment specifications.....	2-1
2-3	Items furnished.....	2-3
2-4	Items required but not furnished	2-3
2-5	Tools and test equipment	2-3
Section II.	Description of operation	2-3
2-6	General	2-3
Section III.	Operating instructions	2-7
2-7	Operating controls and indicators.....	2-7
2-8	Prestart procedures.....	2-9
2-9	Operating procedures.....	2-9
2-9.1	Normal lighting	2-9
2-9.2	Emergency lighting.....	2-9
2-10	Shutdown procedures	2-14
2-10.1	Normal lighting	2-14
2-10.2	Emergency lighting.....	2-14
Section IV.	Maintenance instructions	2-14
2-11	General	2-14
2-11.1	Maintenance concept	2-14
2-11.2	Maintenance procedures.....	2-14
2-12	Preventive maintenance checks and services	2-14
2-13	Troubleshooting.....	2-15

TABLE OF CONTENTS (Continued)

VOLUME 10

	<u>Page</u>
Section V. Storage	2-18
2-14 Short-term storage	2-18
2-15 Administrative storage.....	2-18
2-16 Long-term storage	2-18
CHAPTER 3 EXTERIOR LIGHTING SYSTEM	3-1
Section I. Description and data	3-1
3-1 Description	3-1
3-2 Equipment specifications.....	3-1
3-3 Items furnished.....	3-5
3-4 Items required but not furnished	3-6
3-5 Tools and test equipment.....	3-6
Section II. Description of operation	3-6
3-6 General	3-6
Section III. Operating instructions	3-6
3-7 Operating controls and indicators.....	3-6
3-8 Prestart procedures.....	3-6
3-9 Operating procedures.....	3-6
3-9.1 Exterior side lights	3-6
3-9.2 Floodlights	3-6
3-9.3 Searchlights.....	3-8
3-9.4 Shore discharge hose deployment status lights.....	3-8
3-9.5 Anchor light	3-8
3-9.6 Navigation running lights	3-8
3-10 Shutdown procedures	3-8
3-10.1 Exterior side lights	3-8
3-10.2 Floodlights	3-8
3-10.3 Searchlights.....	3-8
3-10.4 Shore discharge hose deployment status lights.....	3-10
3-10.5 Anchor light	3-10
3-10.6 Navigation running lights	3-10

TABLE OF CONTENTS (Continued)

Section IV.	Maintenance instructions	3-10
3-11	General	3-10
3-11.1	Maintenance concept.....	3-10
3-11.2	Maintenance procedures.....	3-10
3-12	Preventive maintenance checks and services.....	3-10
3-13	Troubleshooting.....	3-10
3-14	Maintenance procedures.....	3-10
3-14.1	General	3-10
3-14.2	Cleaning and replacing bulbs.....	3-10
3-14.2.1	Exterior side lights	3-12
3-14.2.2	Floodlights.....	3-12
3-14.2.3	Searchlights.....	3-13
3-14.2.4	Shore discharge hose deployment status lights.....	3-13
3-14.2.5	Anchor light	3-13
3-14.2.6	Navigation lights.....	3-14
Section V.	Storage.....	3-14
3-15	Short-term storage.....	3-14
3-16	Administrative storage	3-14
3-17	Long-term storage	3-14
CHAPTER 4	EMERGENCY SHUTDOWN.....	4-1
4-1	General	4-1
CHAPTER 5	MANUFACTURERS' SERVICE MANUALS/INSTRUCTIONS.....	5-1
5-1	General	5-1
CHAPTER 6	MANUFACTURERS' WARRANTIES/GUARANTEES	6-1
6-1	General	6-1
LIST OF APPENDICES		
APPENDIX A	REFERENCES.....	A-1
APPENDIX B	MANUFACTURERS' SERVICE MANUALS/INSTRUCTIONS.....	B-1
APPENDIX C	PREVENTIVE MAINTENANCE CHECKS AND SERVICES.....	C-1

TABLE OF CONTENTS (Continued)

VOLUME 10

NOTE

The following appendices, common to all TM's in this series, are in TM-55-1930-209-14&P-18.

- MAINTENANCE ALLOCATION CHART (MAC)
- TOOLS AND TEST EQUIPMENT LIST CTEL)
- EXPENDABLE /DURABLE SUPPLIES AND MATERIALS LIST (ESML)
- REPAIR PARTS AND SPECIAL TOOLS LIST (RPSTL)
- REPAIR PARTS LIST TO FIGURE NUMBER CROSS-REFERENCE LIST

NOTE

The following appendices, common to all TM's in this series, are in TM 55-1930-209-14&P-20.

- COMPONENTS OF END ITEM LIST (COEIL) AND BASIC ISSUE ITEMS LIST (BIILL)
- ADDITIONAL AUTHORIZED ITEMS LIST (AAL)

LIST OF ILLUSTRATIONS

Figure		Page
1-1	Barge Major Components	1-2
2-1	Normal Interior Lighting Arrangement	2-4
2-2	Emergency Interior Lighting Arrangement.....	2-6
2-3	1 OA Rotary Snap Switch (Barge 1 only).....	2-8
2-4	30A 3-Way Rotary Snap Switch	2-8
2-5	Power Panel 3	2-10
2-6	Deck Lighting Panel	2-11
2-7	Void Lighting Panel.....	2-12
2-8	Emergency Lighting Panel.....	2-13
3-1	Exterior Lighting System Arrangement.....	3-4
3-2	24 Vdc Power Panel.....	3-7
3-3	Searchlight	3-9

LIST OF TABLES

Table		Page
2-1	Normal Interior Lighting System Components.....	2-5
2-2	Emergency Interior Lighting System Components	2-7
2-3	Normal Interior Lighting System Troubleshooting	2-15
2-4	Emergency Interior Lighting System Troubleshooting.....	2-16
3-1	Exterior Lighting System Components.....	3-5
3-2	Exterior Lighting System Troubleshooting.....	3-12

CHAPTER 1 INTRODUCTION

Section I. General

1-1 Purpose. This technical manual (TM) describes the operation and maintenance of the lighting systems on Water Purification Barges. Information on other systems installed onboard is in TM 551930-209-14&P-1 thru P-9 and P-11 thru P-17. TM 55-1930-209-14&P-18 and TM 55-1930-209-14&P-20 contains appendices common to all TM's. Location of major barge components is shown in Figure 1-1.

1-2 Scope. The lighting systems onboard the barge provide interior and exterior lighting. Normal and emergency interior lighting is provided in the deckhouse Reverse Osmosis Water Purification Unit (ROWPU) space, dayroom, workshop, and voids. Exterior lighting consists of searchlights and floodlights for use at night or during reduced visibility. Lights on the weatherdecks and standard navigation and status lights are for use during operation and towing.

1-3 Warranties and guarantees. Manufacturers' warranty/guarantee information is in Chapter 6.

1-4 Maintenance forms and records. These are explained in DA PAM 738-750, The Army Maintenance Management System (TAMMS).

1-5 Destruction of Army materiel to prevent enemy use. This shall be as directed in TM 750-244-3.

1-6 Storage. For storage of this system, refer to Section V of Chapters 2 and 3.

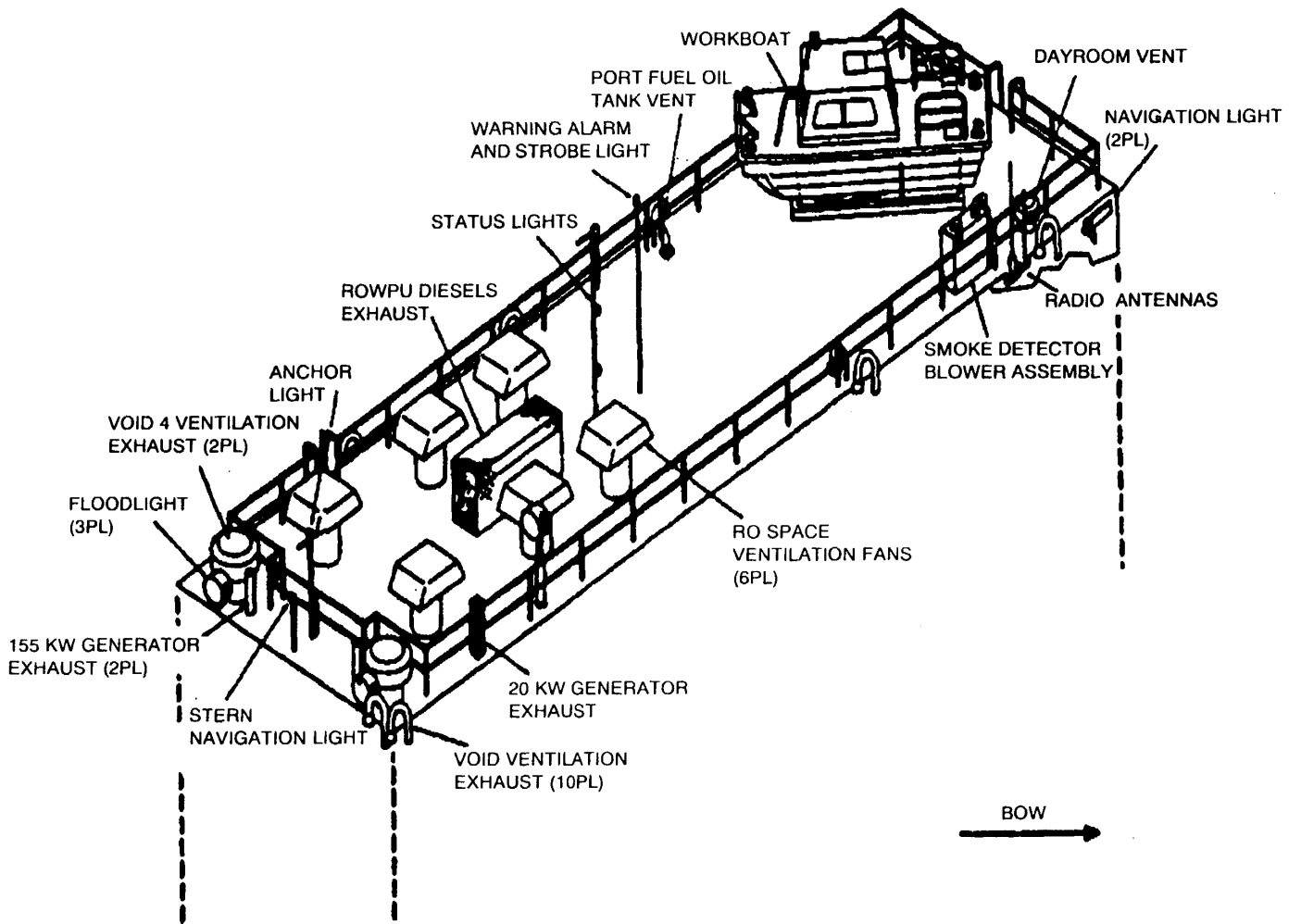

Figure 1-1. Major Components of ROWPU Barge Systems and Equipment - Deckhouse Roof (Sheet 1 of 3)

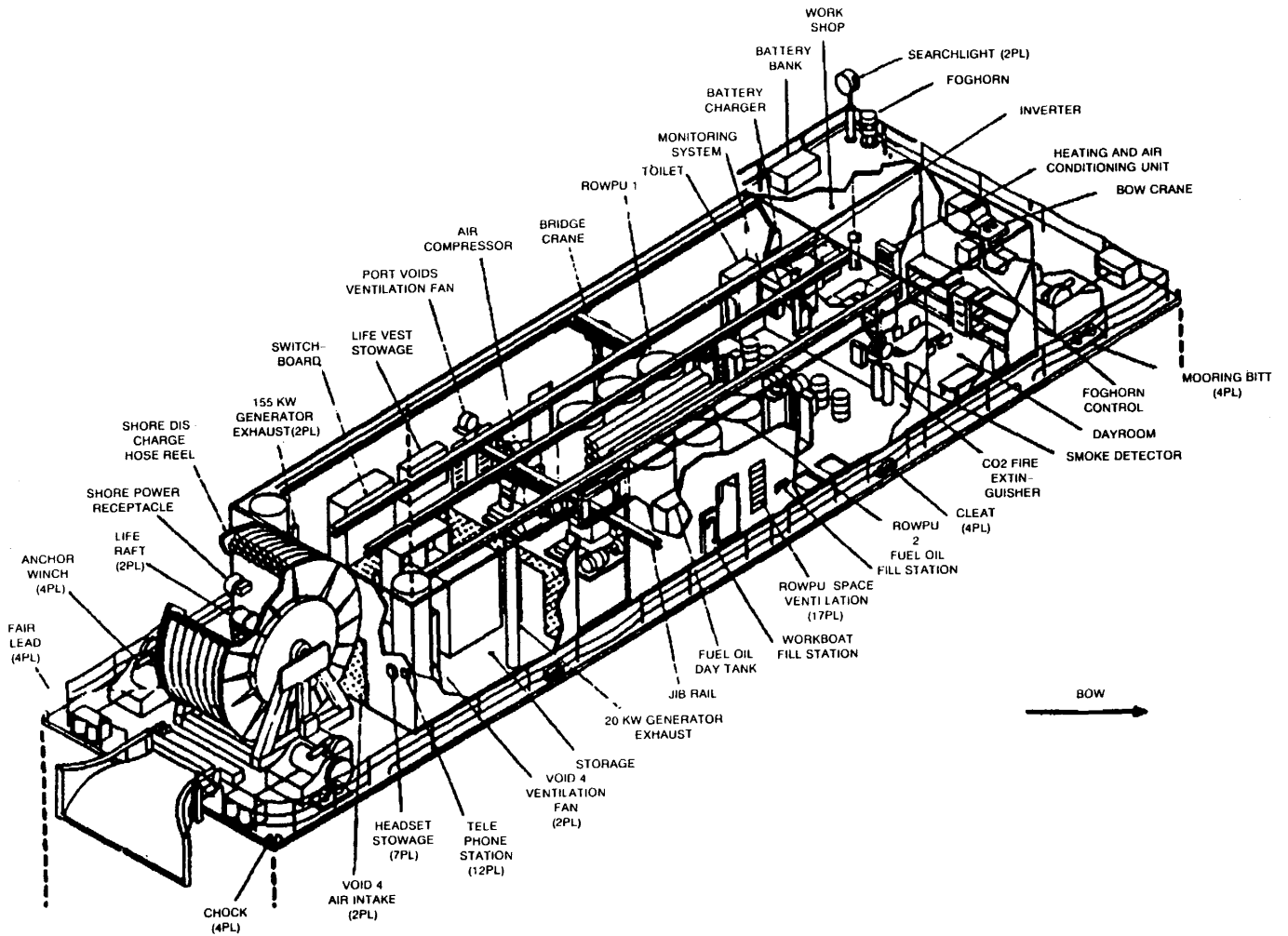

Figure 1-1. Major Components of ROWPU Barge Systems and Equipment -Deckhouse Roof (Sheet 2 of 3)

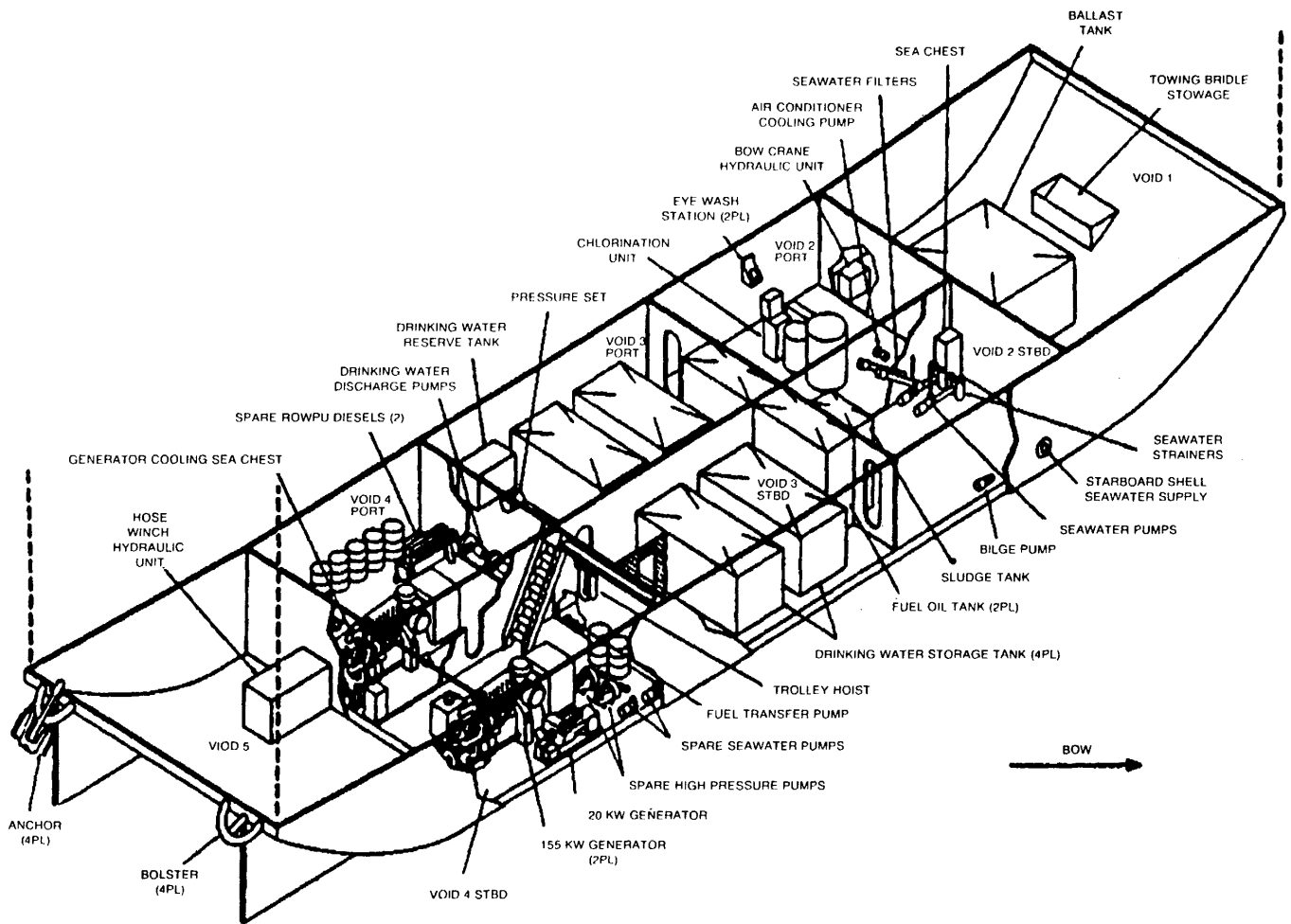

Figure 1-1. Major Components of ROWPU Barge Systems and Equipment -Deckhouse Roof (Sheet 3 of 3)

CHAPTER 2 INTERIOR LIGHTING SYSTEM

Section I. Description and data

2-1 Description. The interior lighting system provides both normal and emergency lighting in the deck house ROWPU space, dayroom, workshop, and voids. The normal lighting system arrangement is shown in Figure 2-1. Components are listed in Table 2-1. The emergency lighting system arrangement is shown in Figure 2-2 and its components are listed in Table 2-2. The normal and emergency lighting system installations are shown in drawings referenced in Appendix A.

2-2 Equipment specifications

a	10A rotary snap switch CAGEC Part No Military specification Type Quantity	81349 M15743/1-001 MIL-S-15743/1 DPST, 125 Vac, submersible 1
b	30A rotary snap switch CAGEC Part No Military specification Type Quantity	81349 M 15743/8-002 MIL-S-15743/8 DPDT, 500 Vac, submersible 2
c	Fluorescent fixture (normal lighting) CAGEC Part No Military specification Mounting Bulb (3) Quantity	80064 M16377/12-333.1 MIL-F-16377/12 Standard w/ white diffusing window assembly 115 Vac, 20W cool white, fluorescent 74 (Barge 1) 77 (Barges 2 & 3)
d	Fluorescent fixture (emergency lighting) Part No Military specification CAGEC Type Mounting Bulb (2) Quantity	M 16377/8-331.1 MIL-F-16377/8 81349 Watertight Standard White diffusing, 20W, 115 Vac 18 (Barge 1)
e	Incandescent red light fixture CAGEC Part No Military specification Type Mounting Bulb Quantity	81349 M16377/27-93.2 MIL-F-16377/2 Watertight Deck 50W, red diffusing 4
f	3 PST door interlocking switch CAGEC Part No Military specification Type Quantity	80064 9000 S6202 74303 S6202-74303 125 Vac, 25A, Type EA52A 1

g	6 PST door Interlocking switch CAGEC Part No Military specification Type Quantity	80064 9000 S6202 74304 S6202-74304 120 Vac, 25A, Type 53A 2
h	Desk lamp CAGEC Part No Military specification Type Mounting Bulb Quantity	81349 M16377/16-141.2 MIL-F-16377/16 Double arm Bulkhead 8W, 120 Vac, fluorescent 1
i	Deck arid void lighting panels CAGEC Part No Military specification Class Rating Branches Quantity	81349 M23928/1-15-DP MIL-P-23928/1 2 50A, 120 Vac 12 2
j	Emergency lighting panel CAGEC Part No Military specification Class Rating Branches Quantity	81349 M23928/2-04-DP MIL-P-23928/2 2 50A, 120 Vac 8 1
k	Transformer CAGEC Manufacturer Specialty Motor Department Part No Type Mounting Rating Quantity	03512 General Electric Company, 9T21B1001G02 Single phase Wall 5 kVA, 120/120 Vac 1
l	Toggle switch (on switchboard) CAGEC Supplier Part No Type Rating Quantity	02929 Newark Electronics 28F1867 Momentary, ON/OFF/ON 5A, 120V 4

m	Indicating light (on switchboard)	
	CAGEC	02929
	Manufacturer	Newark Electronics
	Part No	35F2806
	Type	Slide base
	Rating	120 Vac
	Lens:	
	Part No	35F2790
	Color	Green (Barge 1)
	Blue (Barges 2 and 3)	
	Quantity	1

2-3 Items furnished

2-3.1 Components installed as part of the interior lighting system are listed on the parts list of drawings referenced in Appendix A and in the Components of End Item List in TM 55-1930-209-14&P-20.

2-3.2 Common and bulk items onboard are listed in the Expendable Supplies and Materials List in TM 55-1930- 209-14&P-20.

2-3.3 Repair parts and special tools onboard are listed in the Repair Parts and Special Tools List in TM 55-1930- 209-14&P-1 8

2-4 Items required but not furnished. All required items are furnished.

2-5 Tools and test equipment. Use existing tools and equipment onboard. A complete list of tools and test equipment onboard is in the Tools and Test Equipment List in TM 55-1930-209-14&P-18.

Section II. Description of operation

2-6 General. Power is provided to the normal interior lighting system in the deckhouse and voids by either service generator, the auxiliary generator, or shore power. ROWPU space and void lights are operated from their corresponding lighting panels by closing circuit breakers. Dayroom and workshop lights are operated and controlled from bulkhead-mounted rotary switches. The ROWPU space port and starboard doors and dayroom door to the weatherdeck are each equipped with an interlocking switch that automatically turns off these lights when one of these doors is opened.

In the event that normal power is lost, an inverter automatically converts 24 Vdc battery bank power to 120 Vac power. This power is supplied to the emergency panel for emergency lighting (fluorescent and red incandescent lights) and for communications (marine radio and telephone system).

A green lamp (Barge 1) or blue lamp (Barges 2 and 3), located on the forward panel of the switchboard, indicates that emergency power from the battery bank is available. An emergency light switch is located on the switchboard and next to each door to the weatherdeck so that emergency lights can be readily turned ON/OFF.

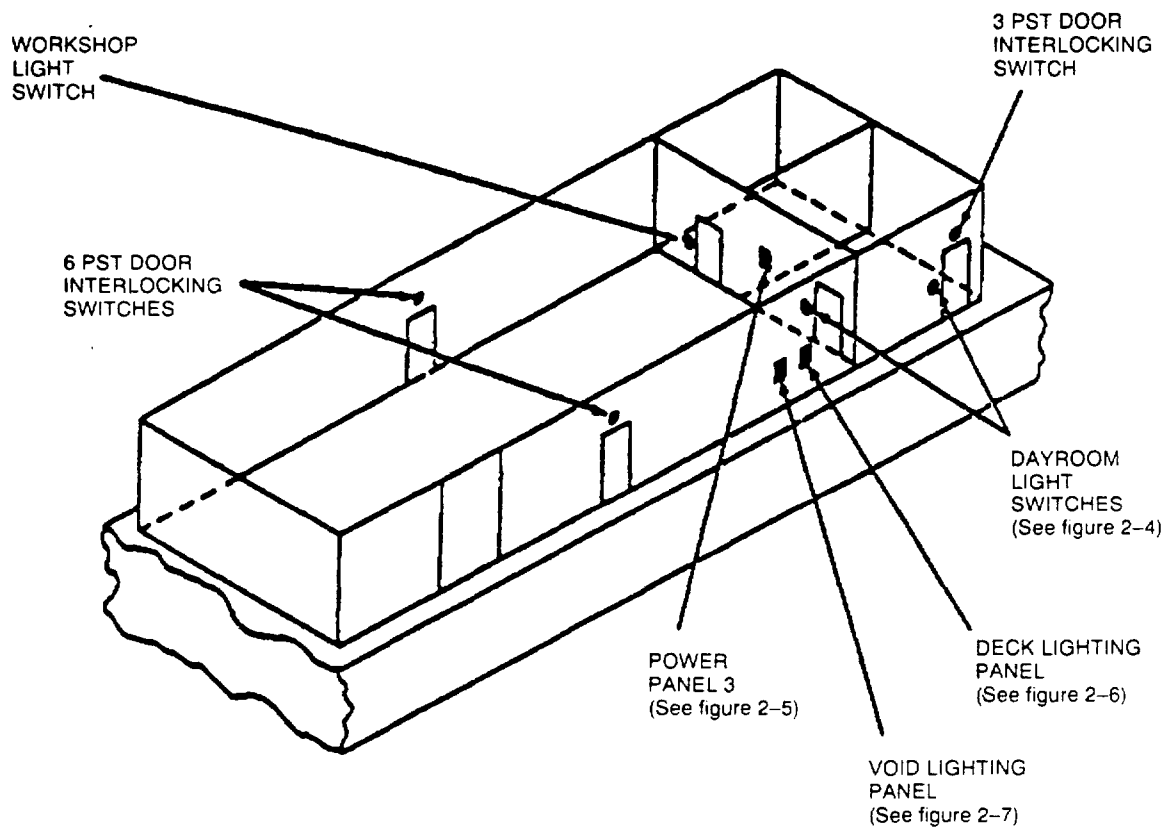

FLUORESCENT LIGHTS

- 33 in ROPWU space
- 4 in Dayroom
- 5 in Workshop
- 4 in Void 1
- 5 In Void 2 Port
- 4 In Void 2 Starboard
- 4 In Void 3 Port
- 3 In Void Starboard (Barge 1)
- 5 in Void 3 Starboard (Barges 2 and 3)
- 4 in Void 4 Port
- 4 in Void 4 Starboard
- 4 in Void 5 (Barge 1)
- 5 in Void 5 (Barges 2 and 3)

Figure 2-1. Normal Interior Lighting Arrangement

Table 2-1. Normal Interior Lighting System Components

<u>Component</u>	<u>Location</u>	<u>Function</u>
Power panel 3	ROWPU space on forward bulkhead	Supplies power to deck, void, and emergency lighting panels, exterior lights, and other deckhouse electrical equipment
Deck lighting panel	ROWPU space on starboard bulkhead forward	Distributes power from power panel 3 circuit breaker 2P13 to ROWPU space, dayroom, and workshop normal lights, searchlights, and other deckhouse equipment
Void lighting panel	ROWPU space on starboard bulkhead forward, near day-room door	Distributes power from power panel 3 circuit breaker 3P13 to normal lights in voids and smoke detector
74 fluorescent lights (Barge 1)	33 in ROWPU space	Provide normal lighting in deckhouse and voids
77 fluorescent lights (Barges 2 & 3)	4 in dayroom 5 in workshop (includes light over workbench) 4 in void 1 5 in void 2 port 4 in void 2 starboard 4 in void 3 port 3 in void 3 starboard (Barge 1) 5 in void 3 starboard (Barges 2 and 3) 4 in void 4 port 4 in void 4 starboard 4 in void 5 (Barge 1) 5 in void 5 (Barges 2 & 3)	
10A rotary snap switch	In workshop by door to ROWPU space (labeled WORKSHOP LIGHTS)	Turns workshop fluorescent lights on/off
30A 3-way rotary snap switch	In dayroom by doors to ROWPU space and weather-deck (labeled DAYROOM LIGHTS)	Turns dayroom lights on/off
3 PST door switch	In dayroom above starboard door	Automatically turns on normal lights in dayroom when door is closed. Automatically turns off lights when door is opened
Two 6 PST door interlocking switches	In ROWPU space above port and starboard doors	Automatically turns on normal lights in ROWPU space when door is closed. Automatically turns off lights when door is opened

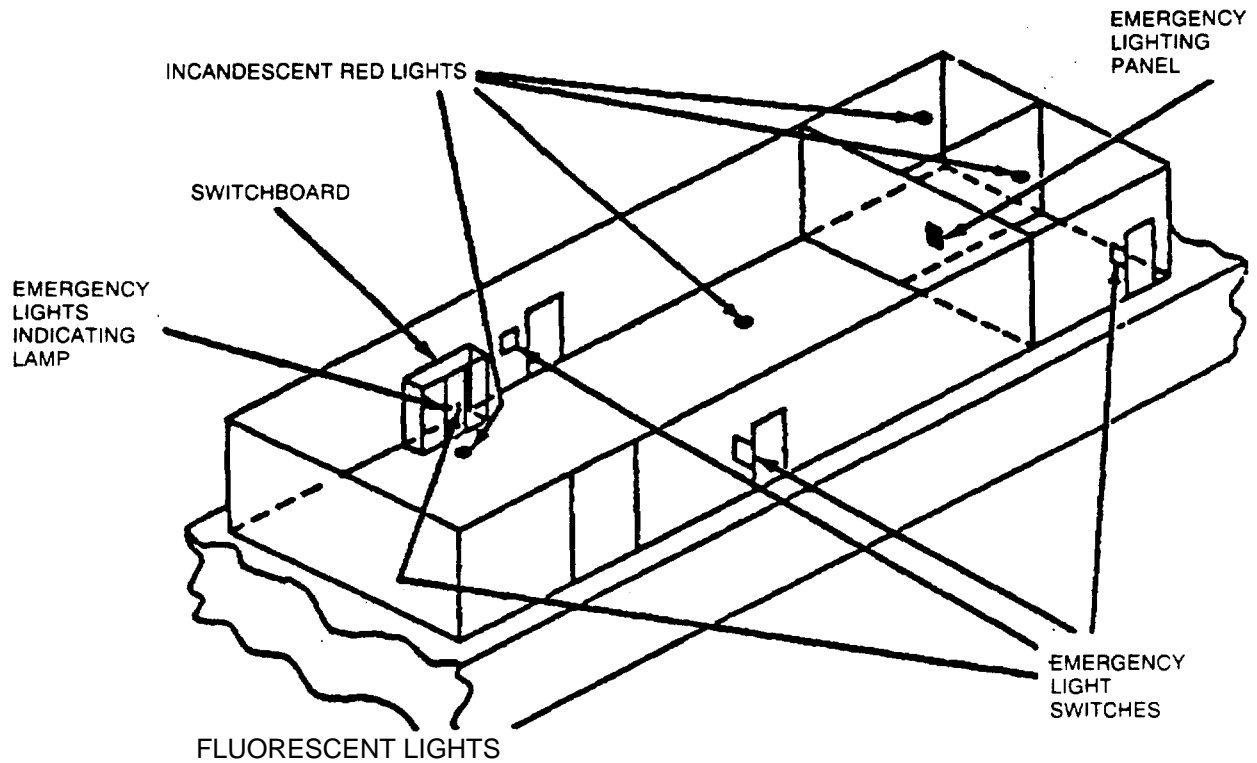

- 6 In ROWPU space
- 1 in Dayroom
- 1 in Workshop
- 1 in Void 1 (Barge 1)
- 2 in Void 1 (Barges 2 and 3)
- 1 In Void 2 Port
- 1 In Void 2 Starboard
- 2 in Void 3 Port
- 2 In Void 3 Starboard
- 1 In Void 4 Port
- 1 in Void 4 Starboard
- 1 in Void 5

Figure 2-2. Emergency Interior Lighting Arrangement

Table 2-2. Emergency Interior Lighting System Components

<u>Component</u>	<u>Location</u>	<u>Function</u>
Emergency lighting panel	ROWPU space on forward bulkhead near power panel 3	Supplies power to ROWPU space, dayroom, workshop, and void emergency fluorescent and red lights
18 fluorescent lights (Barge 1)	6 in ROWPU space	Provide emergency lighting in deck-house and voids
19 fluorescent lights (Barges 2 and 3)	1 in dayroom	
	1 in workshop	
	1 in void 1	
	1 in void 2 port	
	1 in void 2 starboard	
	2 in void 3 port	
	2 in void 3 starboard	
	1 in void 4 port	
	1 in void 4 starboard	
	1 in void 5	
4 incandescent red lights	2 In ROWPU space 1 in workshop 1 in dayroom	Provides lighting for night use when case fluorescents must be blacked out
4 emergency light toggle switches	2 In ROWPU space by port and starboard doors to weatherdeck. 1 on switchboard in ROWPU space. 1 in dayroom by door to weatherdeck	Turns emergency lights throughout barge on/off
Green (Barge 1) or blue (Barges 2 and 3) indicator light	On forward panel of switchboard above emergency light toggle switch	Indicates that emergency power is available from battery bank

Section III. Operating instructions

2-7 Operating controls and indicators. The controls and indicators for the interior lighting systems are listed below. Rotary snap switches are shown in Figures 2-3 and 2-4. Power panels are shown in Figures 2-5 thru 2-8. Circuit breakers within these panels are also labeled, as shown, on the inside of the panel covers.

<u>Control/Indicator</u>	<u>Figure</u>
1 OA rotary snap switch (Labeled WORKSHOP LIGHTS)	2-3
30A 3-way rotary snap switch (labeled DAYROOM LIGHTS)	2-4
Power panel 3 circuit breakers	2-5
Deck lighting panel circuit breakers	2-6
Void lighting panel circuit breakers	2-7
Emergency lighting panel circuit breakers	2-8

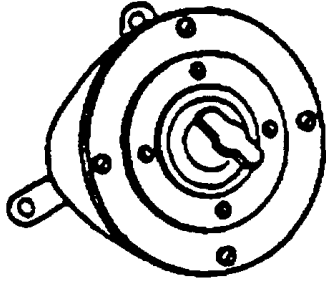

LOCATION IN WORKSHOP
BY DOOR TO ROWPU SPACE
(LBELED WORKSHOP
LIGHTS)

Figure 2-3. 10A Rotary Snap Switch (Barge 1 only)

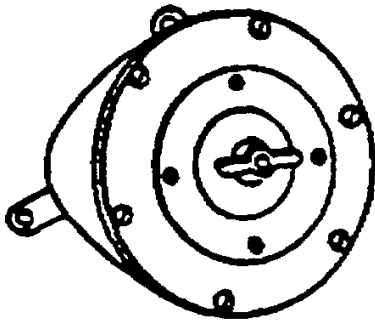

LOCATION,
IN DAYROOM BY DOORS
TO ROWPU SPACE AND
WEATHERDECK(LBELED
DAYROOM LIGHTS)

Figure 2-4. 30A 3-Way Rotary Snap Switch

2-8 Prestart procedures

- a. Perform before operation checks.
- b. Close circuit breaker P13 on switchboard to supply power to power panel 3.
- c. Close circuit breaker 13P13 on power panel 3 (Figure 2-5) to supply power to battery charger.
- d. Close circuit breaker 1 OP13 on power panel 3 (Figure 2-5) to supply power to emergency panel.

2-9 Operating procedures**2-9.1 Normal lighting**

- a. ROWPU space. Close circuit breaker 2P13 on power panel 3 (Figure 2-5) to supply power to deck lighting panel. Close circuit breakers 2P13-1 thru 2P13-4 on deck lighting panel (Figure 2-6) to supply power to fluorescent lights in ROWPU space. Door interlocking switches (blackout switches) automatically turn lights on when the port or starboard doors are closed and turn lights off when either door is opened. Red light stays on when a door is opened.
- b. Dayroom. Close circuit breaker 2P13 on power panel 3 (Figure 2-5) to supply power to deck lighting panel. Close circuit breaker 2P136 on deck lighting panel. Turn fluorescent lights ON in dayroom by operating either of the rotary dayroom light switches located by starboard or aft door. Door interlocking switch (blackout switch) automatically turns fluorescent lights ON when starboard door is closed and turns lights OFF when door is opened. Red light stays ON when door is opened.
- c. Workshop. Close circuit breaker 2P13 on power panel 3 (Figure 2-5) to supply power to deck lighting panel. Close circuit breaker 2P13-5 on deck lighting panel. Turn fluorescent lights ON in workshop by operating rotary workshop light switch located by door to ROWPU space.
- d. Void. Close circuit breaker 3P 13 on power panel 3 (Figure 2-5) to supply power to void lighting panel. Close circuit breakers 3P13-1 thru 3P13-8 on void lighting panel (Figure 2-7) to turn lights ON in voids.

2-9.2 Emergency lighting. If the normal power system fails, the emergency power system automatically keeps emergency lights (white fluorescent and red incandescent) lit. As soon as the failure occurs, the 24 Vdc battery bank on top of the deckhouse supplies power to the inverter. The inverter changes the 24 Vdc power to 120 Vac and supplies the emergency panel.

A green (Barge 1) or blue (Barges 2 and 3) light on the switchboard indicates that emergency power from the 24 Vdc battery bank is available for emergency lighting In the event of power failure. When the circuit breakers listed below are closed, emergency lights can be turned ON or OFF by activating any of the four ON/OFF toggle switches. One switch is near the green (Barge 1) or blue (Barges 2 and 3) light, one near the dayroom starboard door, one near the ROWPU space port door, and one near the ROWPU space starboard door.

- a. ROWPU space. ROWPU space white lights circuit breaker 1 OP1 3A-1 and ROWPU space red lights circuit breaker 10P13A-3 on emergency lighting panel (Figure 2-8).
- b. Dayroom. Workshop, dayroom white lights circuit breaker 10P13A-2 and workshop, dayroom red lights circuit breaker 10P13A-4 on emergency lighting panel.
- c. Workshop. Workshop, dayroom white lights circuit breaker 10P13A-2 and workshop, dayroom red lights circuit breaker 10P13A-4 on emergency lighting panel.
- d. Voids. Voids 1 and 2 white lights circuit breaker 1 OP1 3A-5 and voids 3, 4, and 5 white lights circuit breaker 10P13A-6 on emergency lighting panel.

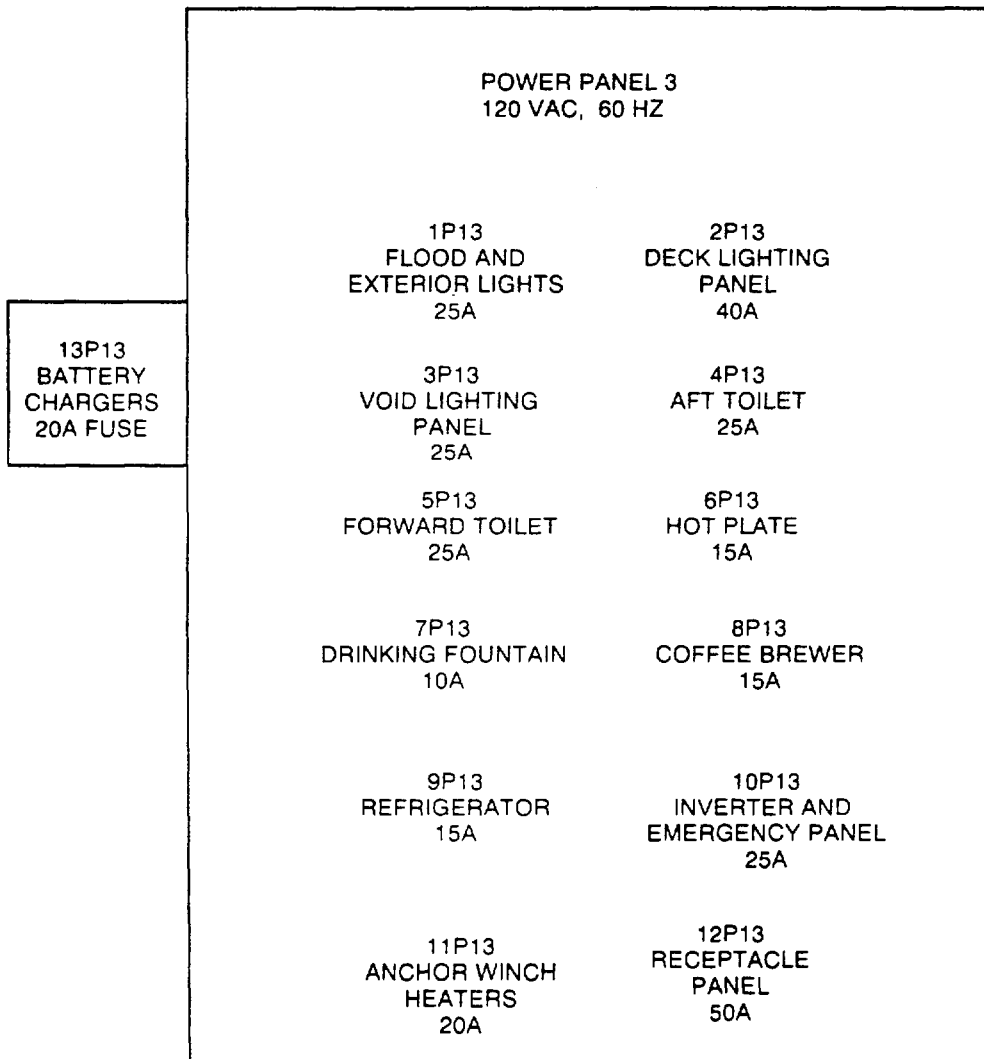

LOCATED IN ROWPU SPACE ON FORWARD BULKHEAD.

Figure 2-5. Power Panel 3

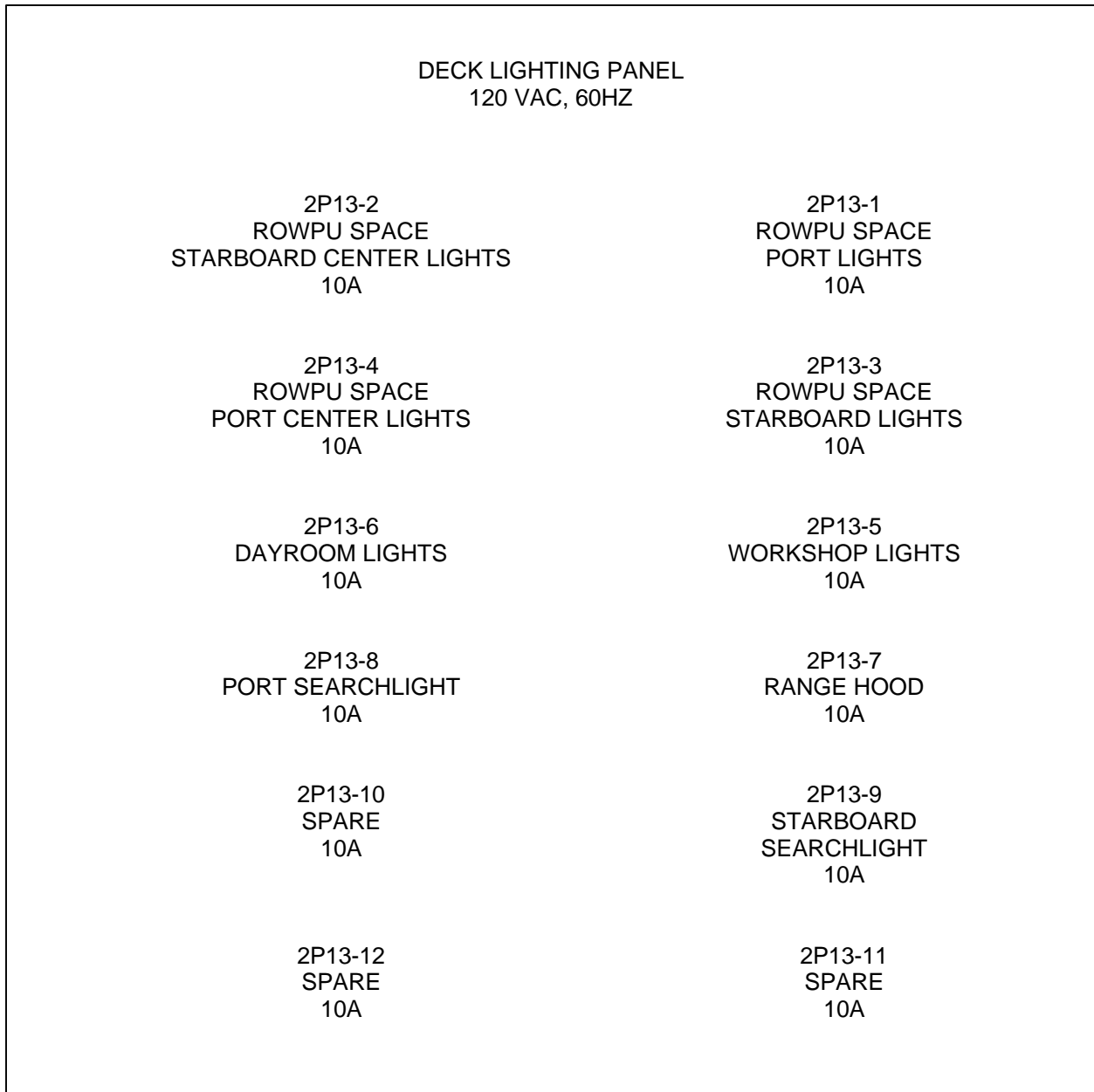

LOCATED IN ROWPU SPACE ON STARBOARD BULKHEAD FORWARD.

Figure 2-6 . Deck Lighting Panel

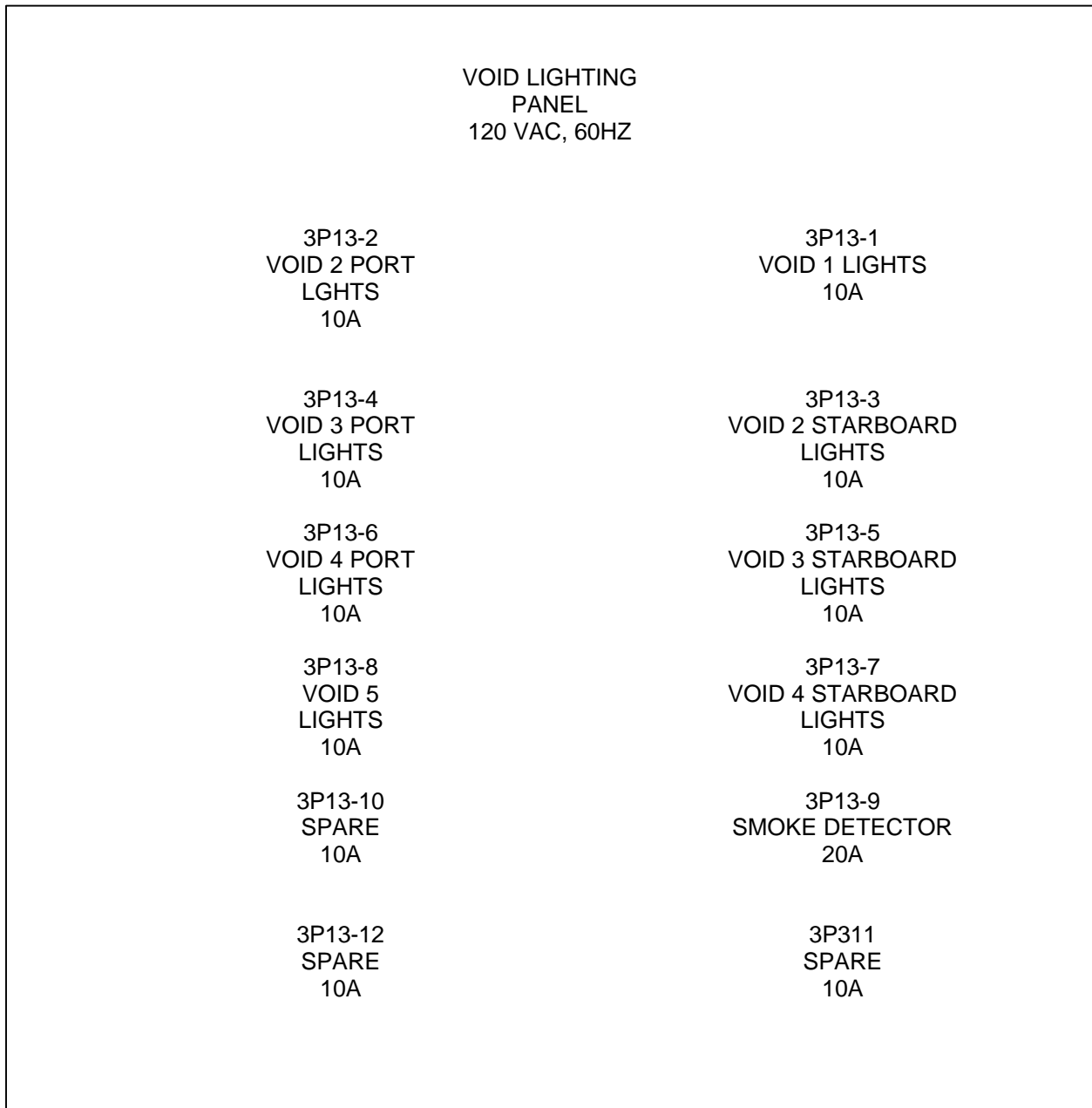

LOCATED IN ROWPU SPACE ON STARBOARD BULKHEAD FORWARD.

Figure 2-7. Void Lighting Panel

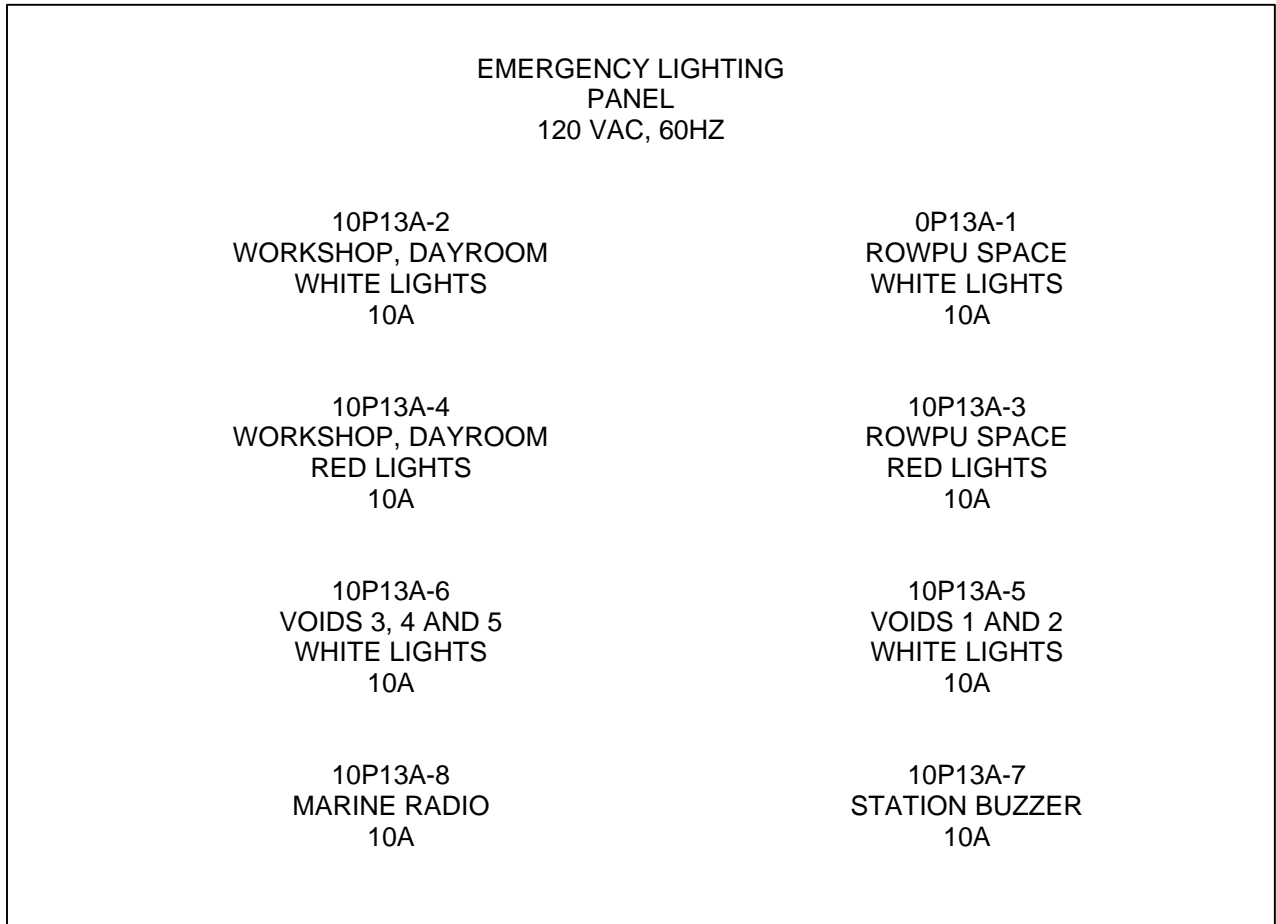

LOCATED IN ROWPU SPACE ON FORWARD BULKHEAD NEAR POWER
PANEL 3

Figure 2-8 . Emergency Lighting Panel

2-10 Shutdown procedures

2-10.1 Normal lighting

- a. Turn ROWPU space fluorescent lights OFF by opening circuit breaker 2P13-1 thru 2P13-4 on deck lighting panel.
- b. Turn dayroom fluorescent lights OFF by operating either of the rotary snap switches in the dayroom or by opening circuit breaker 2P13-6 on deck lighting panel.
- c. Turn workshop fluorescent lights OFF by operating rotary snap switch in workshop or by closing circuit breaker 2P13-5 on deck lighting panel.
- d. Turn fluorescent lights OFF in the voids by opening circuit breakers 3P13-1 thru 3P13-8 on void lighting panel.

2-10.2 Emergency lighting

To turn all emergency lights OFF (fluorescent and red), operate any of the four emergency light toggle switches, circuit breakers, inverter, or inverter circuit breaker.

Section IV. Maintenance instructions

2-11 General

2-11.1 Maintenance concept

2-11.1.1 Unit level and Intermediate Direct Support and Intermediate General Support (IDS/IGS) maintenance on the interior lighting system is performed onboard by barge crewmembers whenever possible.

2-11.1.2 Any IDS/IGS maintenance beyond capability of crewmembers is provided by a shore-based area support maintenance unit. This unit also determines if depot support maintenance is required.

2-11.1.3 Intermediate support maintenance is accomplished by replacement of components or major end items.

2-11.1.4 Unless other intermediate support procedures are directed, IDS/IGS maintenance normally is provided by an Army Transportation Corps floating craft intermediate support maintenance unit serving terminal operating area. Components to be disposed of are processed by this unit.

2-11.1.5 Maintenance Allocation Chart (MAC) is in TM 55-1930-209-14&P-18. For maintenance of other equipment onboard, consult appropriate manual.

2-11.2 Maintenance procedures. Maintenance instructions are contained in the following paragraphs: Appendix C, Preventive maintenance checks and services; and paragraph 2-13, Troubleshooting.

2-12 Preventive maintenance checks and services. See TM 55-1930-209-14&P-10, Appendix C for preventive maintenance checks and services for the lighting system. See TM 55-1930-209-14&P-19 for complete preventive maintenance checks and services for all systems on the ROWPU Barge.

2-13 Troubleshooting. Troubleshoot normal interior lighting system as given in Table 2-3 and the emergency interior lighting system as given in Table 2-4.

Table 2-3. Normal Interior Lighting System Troubleshooting

<u>Condition</u>	<u>Possible Cause</u>	<u>Suggested Action</u>
1 ROWPU space overhead fluorescent lights do not come on when any circuit breaker 2P13-1 thru 2P13-4 (Figure 2-6) is closed	a. Circuit breaker 2P13 on power panel 3 open	a. Close circuit breaker
	b. Circuit breaker P13 on switchboard open	b. Close circuit breaker
	c. Port or starboard door open	c. Close door
	d. Bulb(s) burned out	d. Replace bulb(s)
	e. Door interlocking (black-out) switch locked in open position	e. Make sure switch is operating normally
	f. Faulty circuit	f. Check circuit
2. Dayroom overhead fluorescent lights do not come on when either dayroom rotary light switch is turned on	g. Circuit breaker P13 on switchboard open	g. Close circuit breaker
	a. Circuit breaker 2P13-6 on deck lighting panel open	a. Close circuit breaker
3. Emergency fluorescent lights in ROWPU space do not come on	Circuit breaker 2P13 on power panel 3 open	b. Close circuit breaker
	a. Circuit breaker 10P13A-1 on emergency lighting panel open	a. Close circuit breaker
	b. Bulb(s) burned out	b. Replace bulb(s)
	c. Starboard door open	c. Close starboard door
	d. Door interlocking (black-out) switch locked in open position	d. Make sure switch is operating normally
	e. Dayroom rotary switches malfunctioning	e. Replace switches
4. Workshop overhead fluorescent lights do not come on when rotary workshop light switch is turned on	f. Faulty circuit	f. Check circuit
	a. Circuit breaker 2P13-5 on deck lighting panel open	a. Close circuit breaker
	b. Circuit breaker 2P13 on power panel 3 open	b. Close circuit breaker
	c. Circuit breaker P13 on switchboard open	c. Close circuit breaker
	d. Bulb(s) burned out	d. Replace bulb(s)
	e. Workshop rotary switch malfunctioning	e. Replace switch
	f. Faulty circuit	f. Check circuit

Table 2-4. Emergency Interior Lighting System Troubleshooting

<u>Condition</u>	<u>Possible Cause</u>	<u>Suggested Action</u>
1 Emergency lights do not come on when normal lighting fails	a Circuit breakers 10P13A-1 thru 10P13A-6 on emergency lighting panel open	a Close circuit breakers
	b Circuit breaker 10P13 on power panel 3 open	b Close circuit breaker
	c Circuit breaker P13 on switchboard open	c Close circuit breaker
	d Faulty circuits	d Check circuit
	e Bulb(s) burned out	e Replace bulb(s)
	f Emergency power system malfunctioning	f Troubleshoot (TM 55-1930-209-14 & P-9)
	g Inverter turned off	g Turn inverter on
	h Emergency lights not in standby mode	h Turn on emergency lights
2 Green (Barge 1) or blue (Barges 2 and 3) light on switchboard is off	a Battery power is low	a Charge or replace batteries
	b Battery charger malfunctioning	b Replace fuse In battery charger
	c Circuit breaker 10P13 on power panel 3 open	c Close circuit breaker
	d Circuit breaker P13 on switchboard open	d Close circuit breaker
	e Port or starboard door open	e Close door
	f Door interlocking (blackout) switches locked in open position	f Make sure switches are operating normally
3 Void overhead fluorescent lights do not come on when any circuit breaker 3P13-1 thru 3P13-8 (Figure 2-7) is closed	a Circuit breaker 3P13 on power panel 3 open	a Close circuit breaker
	b Circuit breaker P13 on switchboard open	b Close circuit breaker
	c Faulty circuit	c Check circuit
	d Bulb(s) burned out	d Replace bulb(s)
4 Emergency fluorescent lights in ROWPU space do not come on (continued)	a Bulb(s) burned out	a Replace bulb(s)
5 Emergency fluorescent light in dayroom does not come on	b Faulty circuits	b Check circuits
	a Circuit breaker 10P13A-2 on emergency lighting panel open	a Close circuit breaker
	b Circuit breaker 10P13 on power panel 3 open	b Close circuit breaker

Table 2-4. Emergency Interior Lighting System Troubleshooting (continued)

Condition	Possible Cause	Suggested Action	
6	Emergency fluorescent light in workshop does not come on	c Circuit breaker P13 on switchboard open	c Close circuit breaker
		d Starboard door open	d Close starboard door
7	Emergency fluorescent lights in void 1, void 2 port, or void 2 starboard do not come on	e Starboard door interlocking (blackout) switch locked in open position	e Make sure switch is operating normally
		f Bulb burned out	f Replace bulb
8	Emergency fluorescent lights in void 3 port, void 3 starboard, void 4 port, void 4 starboard, or void 5 do not come on	g Faulty circuits	g Check circuits
		Same as a, b, c, f, and g in problem 5	Same as a, b, c, f, and g in problem 5
9	Red lights in ROWPU space do not come on	a Circuit breaker 10P13A-5 on emergency lighting panel open	a Close circuit breaker
		b Same as b, c, f, and g in problem 5	b Same as b, c, f, and g
10	Red light in dayroom does not come on	a Circuit breaker 10P13A-6 on emergency lighting panel open	a Close circuit breaker
		b Same as b, c, f, and g in problem 3	b Same as b, c, f, and g
11	Red light in workshop does not come on	a Circuit breaker 10P13A-3 on emergency panel open	a Close circuit breaker
		b Same as b, c, f, and g in problem 2	b Same as b, c, f, and g in problem 2
12	Red light in workshop does not come on	a Circuit breaker 10P13A-4 on emergency lighting panel open	a Close circuit breaker
		b Same as b, c, f, and g in problem 3	b Same as b, c, f, and g in problem 3
13	Red light in workshop does not come on	a Circuit breaker 1 OP1 3A-4 on emergency panel open	a Close circuit breaker
		b Same as b, c, f, and g in problem 3	b Same as b, c, f, and g in problem 3

Section V. Storage

2-14 Short-term storage. If barge is taken out of service for more than 7 days but less than 30 days, and interior lighting system will not be used while In storage, follow shutdown procedures in paragraph 2-10. Check for corrosion, damage, and pilferage. Correct as necessary.

2-15 Administrative storage. If barge is taken out of service for more than 30 days but less than 6 months, barge remains a unit responsibility and shall be maintained by unit personnel. Check for corrosion, damage, and pilferage.

Correct as necessary.

2-16 Long-term storage. If barge is to be taken out of service for 6 months or more, turn it in to depot for preparation and placement into long-term storage. If barge is in administrative storage and is to be taken out of service and placed in depot long-term storage (6 months or more), process interior lighting system for normal operations as specified in the following steps before releasing to depot.

- a. Perform the before operation checks.
- b. Check that the interior lighting system operates satisfactorily while performing the procedures in paragraphs 2-9.1 and 2-10.1.
- c. Perform during operation checks.

CHAPTER 3 EXTERIOR LIGHTING SYSTEM

Section I. Description and data

3-1 Description. The exterior lighting system provides lighting for navigation, night operations, and for working on the weatherdeck. The system's arrangement is shown in Figure 3-1 and its components are listed in Table 3-1. Installation is shown on drawings listed in Appendix A. Additional information about components is contained in the manufacturers' service manuals/instructions in Appendix B.

3-2 Equipment specifications

- a. Floodlight
 - CAGEC 81349
 - Part No M 16377/61-303.1
 - Military specification MIL-F-16377/61
 - Type II
 - Class 2
 - Rating 120V, 300W
 - Lamp:
 - Military standard part no MS15535-6
 - Type Sealed beam, wide flood
 - Rating 120 Vac, 300W
 - Quantity 3
- b. Green navigation running light
 - CAGEC 46576
 - Manufacturer Perko Inc.
 - Part No Figure No 1127-GA
 - Type Navigation side light
 - Lens Green
 - Rating 24 Vdc, 0.42A
 - Bulb:
 - Manufacturer Perko Inc.
 - CAGEC 46576
 - Figure No 374-2
 - Color Clear
 - Type T-8
 - Base Double contact
 - Rating 24 Vdc, 15W
 - Quantity 1
- c. Red navigation running light
 - Manufacturer Perko Inc.
 - CAGEC 46576
 - Part No Figure No 1127-RA
 - Type Navigation side light
 - Rating 24 Vdc, 0.42A
 - Lens Red
 - Bulb:
 - Manufacturer Perko Inc.
 - CAGEC 46576
 - Part No Figure No 374-2
 - Color Clear
 - Type T-8
 - Base Single contact
 - Rating 24 Vdc, 15 W
 - Quantity 1

d. Junction box	
Manufacturer	Midland-Ross Corporation Electrical Products
CAGEC	Division
Part No.	78229
Color	52171-1/2
Type	Clear
Size	Non-watertight
Cover:	4inx4inx2 1/8in
Part No.	52-C-D
Size	4 in x 4 in flat
Quantity	6
e. Red shore discharge hose deployment status light	
Manufacturer	Aqua Signal
CAGEC	61204
Part No.	70
Supplier	W. H. Swann
	1830 Azaka Garden Road
	Norfolk, VA 23320
Rating	24 Vdc
Visibility area	360 degrees
Lens:	
Part No.	83070-006
Color	Red
Bulb'	
Part No.	904-00171
Rating	24 Vdc, 40W
Quantity	2
f. White shore discharge hose deployment status light	
Manufacturer	Aqua Signal
CAGEC	61204
Part No.	70
Supplier	W. H. Swann
Rating	24 Vdc
Visibility area	360 degrees
Lens:	
Part No.	83070-004
Color	White
Bulb:	
Part No.	904-00171
Rating	24 Vdc, 40W
Quantity	1
g. Rotary snap switch	
CAGEC	81349
Part No.	M 15743/1-001
Military specification	MIL-S-15743/1
Type	On-off, DPST, SPF
Quantity	2

<p>h Rotary snap switch CAGEC Part No Military specification Type Quantity</p>	<p>81349 M15743/8-001 MIL-S-15743/8 DPDT, 125V, watertight 1</p>
<p>i Searchlight Manufacturer CAGEC Model No Size 12 in Bulb: Part No Rating Quantity</p>	<p>Perko Inc. 47576 883-2 with 844 bulb and socket 2-12-844 1790000 CP, 120 Vac 2</p>
<p>j Exterior side light Manufacturer CAGEC Part No Type Rating Mounting Quantity</p>	<p>Midland-Ross Corporation Russelstoll Division 78011 LVWA 15G Vaportight 150W Bulkhead 10</p>
<p>k White navigation running light Manufacturer CAGEC Part No Type Rating LensWhite Bulb: Manufacturer CAGEC Type Base Rating Quantity</p>	<p>Perko Inc. 46576 1129A Navigation stern light 24 Vdc, 0.42A Perko Inc. 46576 T-8 Single contact 24 Vdc, 15 W 1</p>
<p>l White anchor light Manufacturer CAGEC Part No Type Rating Visibility area Lens Quantity</p>	<p>Perko Inc. 46576 Figure No.1 130A Anchor 24 Vdc 360 degrees White 1</p>

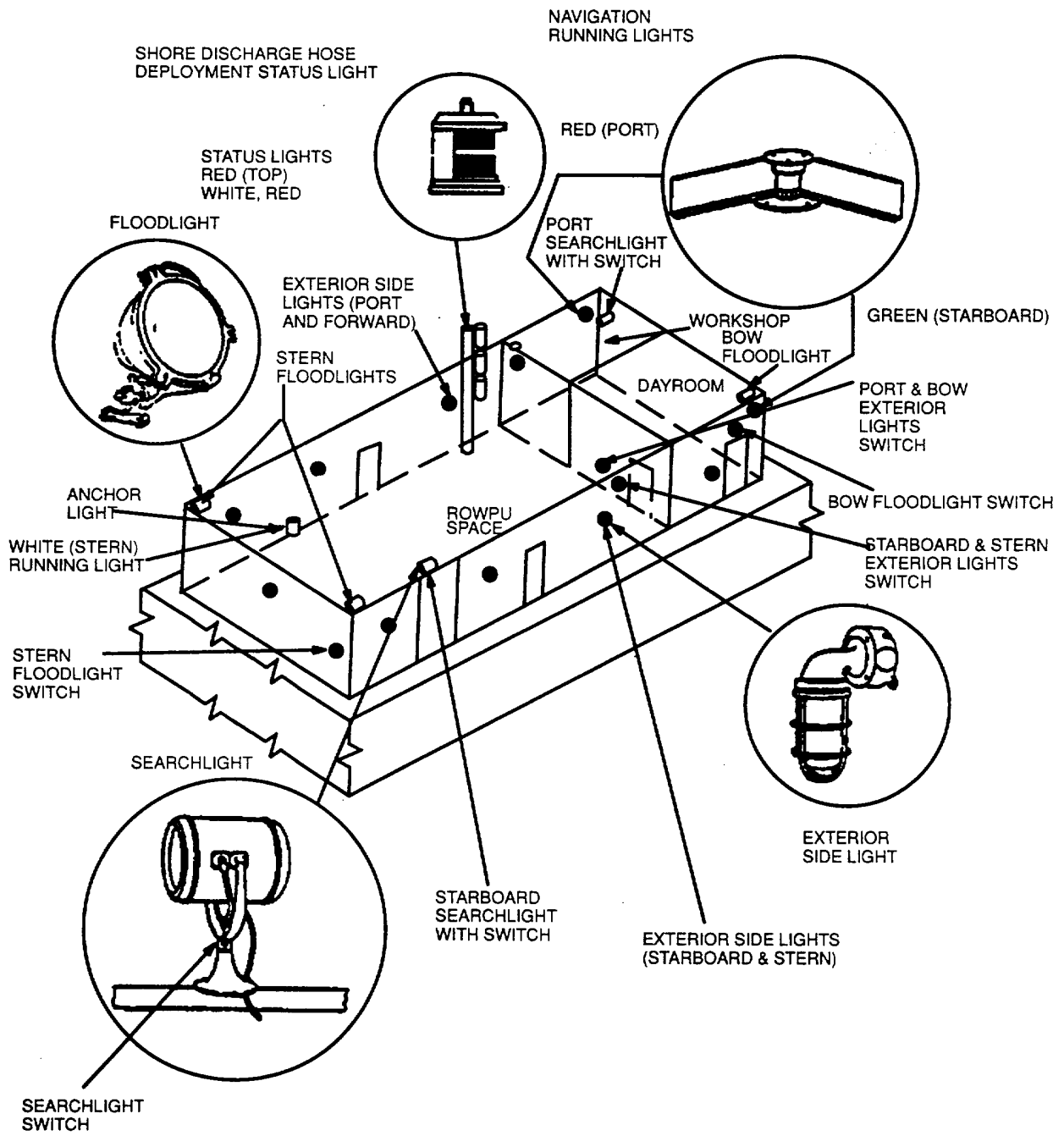

Figure 3-1 . Exterior Lighting System Arrangement

Table 3-1. Exterior Lighting System Components

Component	Location	Function
10 exterior side lights	Exterior of deckhouse: 1 on forward (bow) bulkhead 4 on port bulkhead 4 on starboard bulkhead 1 on aft (stern) bulkhead	Provide lighting for weatherdeck
4 on/off rotary snap switches labeled PORT & BOW EXTERIOR LIGHTS, STARBOARD & STERN EXTERIOR LIGHTS, BOW FLOODLIGHT, and STERN FLOODLIGHTS	1 on forward bulkhead in ROWPU space	Turns port and bow exterior lights on/off
	1 on forward bulkhead in ROWPU space	Turns bow and starboard exterior lights on/off
	1 on exterior of deckhouse on bow	Turns bow floodlight on/off
2 switches on searchlights	1 on exterior of deckhouse on stern	Turns two stern floodlights on/off
	1 on base of each search light	Turns searchlight on/off
3 floodlights	1 on bow 2 on top of deckhouse aft (one port, one starboard)	Provide lighting for deck
2 searchlights	On top of deckhouse 1 port side forward 1 starboard side aft	Provide lighting for bow stern areas and used for signaling
3 shore discharge hose deployment status lights (1 white, 1 red)	On forward mast is deployed to shore	Provide warning that discharge hose
Anchor light	Aft on top of deckhouse on center line	Indicates that barge is anchored
Green (starboard) navigation running lights	Exterior of deckhouse on	Provides light for navigation starboard side forward
Red (port) navigation running light	Exterior of deckhouse on portside forward	Provides light for navigation
White (stern) navigation running light	Aft on top of deckhouse on center line	Provides light for navigation

3-3 Items furnished

3-3.1 Components installed as part of the exterior lighting system are listed on the parts list of drawings referenced in Appendix A and in the Components of End Item List in TM 55-1930-209-14&P-20.

3-3.2 Common and bulk items onboard are listed in the Expendable Supplies and Materials List in TM 55-1930-209-14&P-20.

3-3.3 Repair parts and special tools onboard are listed in the Repair Parts and Special Tools List in TM 55-1930-209-14&P-18.

3-4 **Items required but not furnished.** All required items are furnished.

3-5 Tools and test equipment. Use existing tools and equipment onboard. A complete list of tools and test equipment onboard is in the Tools and Test Equipment List in TM 55-1930-209-14&P-18.

Section II. Description of operation

3-6 **General.** Power is provided to the exterior side lights, floodlights, and searchlights by either service generator, the auxiliary generator, or shore power. Exterior side lights are operated from bulkhead-mounted rotary switches located in the ROWPU space. Floodlights are also operated from bulkhead-mounted rotary switches. Searchlights are operated from base-mounted rotary switches.

Power is provided to the shore discharge hose deployment status lights, anchor light, and navigation lights by the 24 Vdc power panel. All of these lights are operated by closing circuit breakers on the 24 Vdc power panel.

Section III. Operating instructions

3-7 **Operating controls and indicators.** The controls and indicators for the exterior lighting system are listed below. Power panel covers are labeled as shown in Figures 2-5 thru 2-8 and 3-2. Circuit breakers within these panels are also labeled, as shown, on the inside of panel covers.

<u>Control/Indicator</u>	<u>Figure</u>
Rotary snap switches (labeled as	2-3
PORT & BOW EXTERIOR LIGHTS,	2-4
STARBOARD & STERN EXTERIOR LIGHTS,	
BOW FLOODLIGHT and STERN FLOODLIGHTS.	
Local on/off switch on each searchlight	
Power panel 3 circuit breakers	2-5
Deck lighting panel circuit breakers	2-6
24 Vdc power panel circuit breakers	3-2

3-8 **Prestart procedures.** Perform before operation checks.

3-9 **Operating procedures**

3-9.1 **Exterior side lights**

- a. Close circuit breaker P13 on switchboard to supply power to power panel 3.
- b. Close circuit breaker 1 P13 on power panel 3 to supply power to exterior lights and floodlights.
- c. Turn one bow and four port exterior lights ON by operating PORT & BOW EXTERIOR LIGHTS rotary switch located in ROWPU space by dayroom door.
- d. Turn one aft and four starboard exterior lights ON by operating STARBOARD & STERN EXTERIOR LIGHTS rotary switch located in ROWPU space by dayroom door.

3-9.2 **Floodlights**

- a. Perform steps a and b In paragraph 3-9.1.
- b. Turn bow floodlight ON by operating BOW FLOODLIGHT rotary switch located on weatherdeck on deckhouse forward bulkhead
- c. Turn aft floodlights ON by operating STERN FLOODLIGHTS rotary switch located on weatherdeck on deckhouse aft bulkhead.

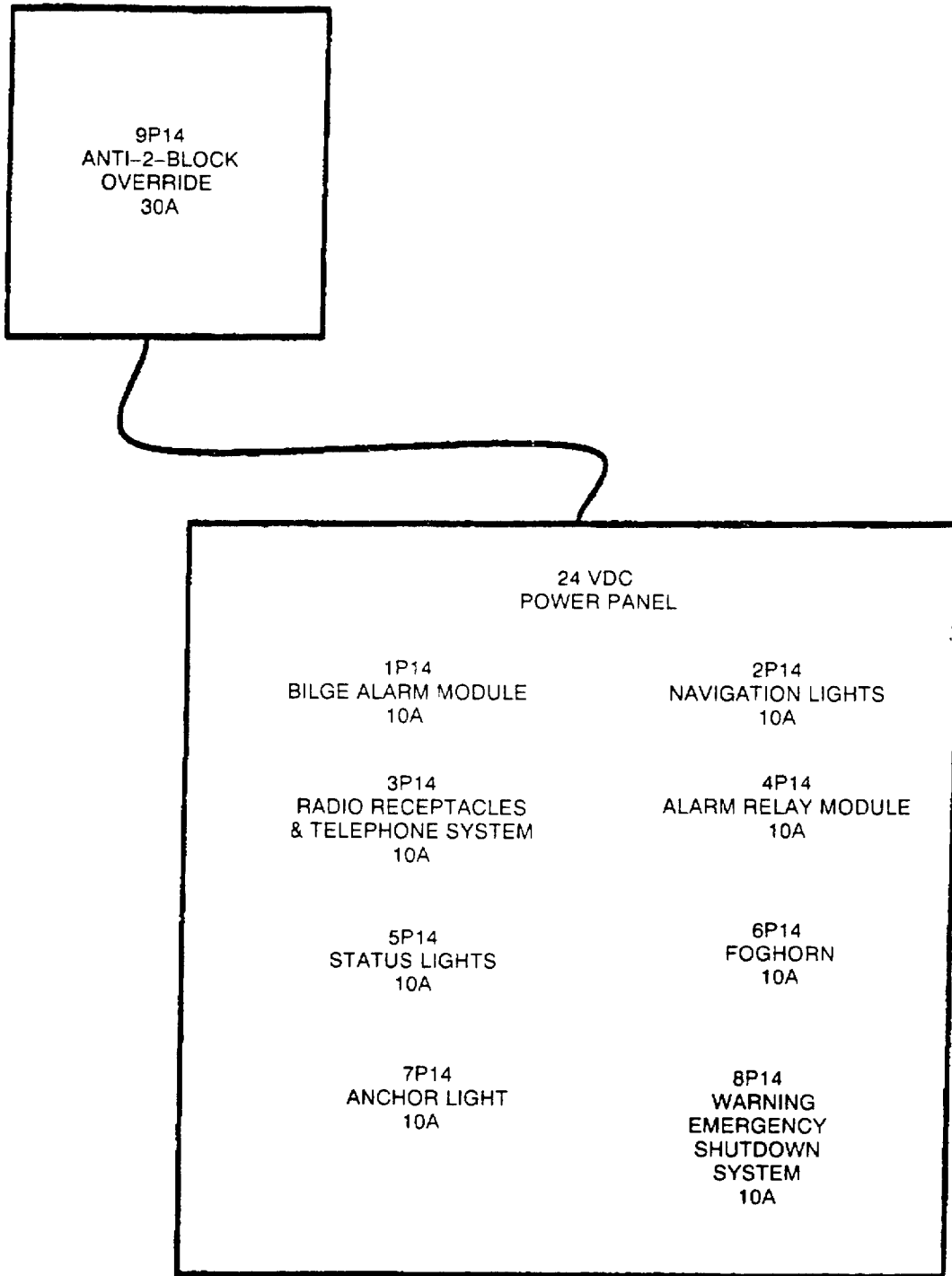

LOCATED IN WORKSHOP ON AFT BULKHEAD

Figure 3-2 . 24 Vdc Power Panel

3-9.3 Searchlights

- a. Close circuit breaker P13 on switchboard to supply power to power panel 3.
- b. Close circuit breaker 2P13 on power panel 3 to supply power to deck lighting panel.
- c. Turn port (forward) searchlight ON by closing circuit breaker 2P13-8 on deck lighting panel. Operate rotary ON/OFF switch located on searchlight base (Figure 3-3).
- d. Turn starboard (aft) searchlight ON by closing circuit breaker 2P13-9 on deck lighting panel. Operate rotary ON/OFF switch located on searchlight base.
- e. Rotate searchlight as desired to illuminate target.

3-9.4 Shore discharge hose deployment status lights

NOTE

When shore discharge hose is deployed during periods of darkness, maritime regulations require that status lights be shown on forward mast in following sequence and scheme: red on top, white in middle, and red on bottom. During daylight hours, black signal shapes must be displayed on forward mast in following sequence and scheme: round on top, diamond in middle, and round on bottom.

- a. Plug in three status light plugs in receptacle on top of deckhouse.
- b. Close (ON) circuit breaker 5P14 on 24 Vdc power panel to turn on red and white status lights.

3-9.5 Anchor light. Close (ON) circuit breaker 7P14 on 24 Vdc power panel to turn on white anchor light.

NOTE

When barge is anchored at night, maritime regulations require that a white anchor light be displayed.

3-9.6 Navigation running lights. Close (ON) circuit breaker 2P14 on 24 Vdc power panel to turn on navigation lights (starboardside green light, portside red light, and white stern light).

3-10 Shutdown procedures

3-10.1 Exterior side lights

- a. Turn bow and port exterior lights OFF by operating PORT & BOW EXTERIOR LIGHTS rotary switch located in ROWPU space by dayroom door.
- b. Turn aft and starboard exterior lights OFF by operating STARBOARD & STERN EXTERIOR LIGHTS rotary switch located in ROWPU space by dayroom door.

3-10.2 Floodlights

- a. Turn bow floodlight OFF by operating BOW FLOODLIGHT rotary switch located on weatherdeck on deckhouse forward bulkhead.
- b. Turn aft floodlights OFF by operating STERN FLOODLIGHTS rotary switch located on weatherdeck on deckhouse aft bulkhead.

3-10.3 Searchlights. Turn the rotary ON/OFF switch located on searchlight base to OFF.

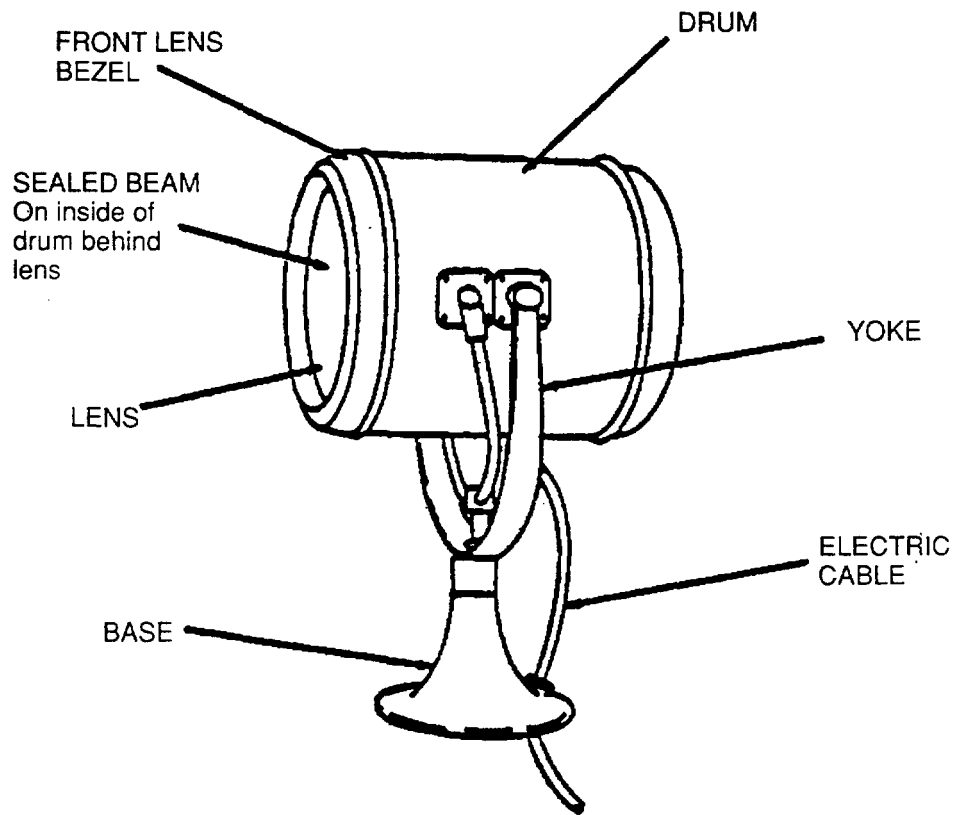

NOTE:

One searchlight is located on top of deckhouse on the forward port corner, the other near the aft starboard corner. A rotary on/off switch is located on the base of each searchlight.

Figure 3-3. Searchlight

3-10.4 Shore discharge hose deployment status lights. Turn red and white status lights OFF by opening circuit breaker 5P14 on 24 Vdc power panel.

3-10.5 Anchor light. Turn anchor light OFF by opening circuit breaker 7P14 on 24 Vdc power panel.

3-10.6 Navigation running lights. Turn navigation lights OFF by opening circuit breaker 2P14 on 24 Vdc power panel.

Section IV. Maintenance instructions

3-11 General

3-11.1 Maintenance concept

3-11.1.1 Unit level and IDS/IGS maintenance on the exterior lighting system is performed onboard by barge crewmembers whenever possible.

3-11.1.2 Any IDS/IGS maintenance beyond capability of crewmembers is provided by a shore-based area support maintenance unit. This unit also determines if depot support maintenance is required.

3-11.1.3 Intermediate support maintenance is accomplished by replacement of components or major end items.

3-11.1.4 Unless other Intermediate support procedures are directed, IDS/IGS maintenance normally is provided by an Army Transportation Corps floating craft Intermediate support maintenance unit serving terminal operating area Components to be disposed of are processed by this unit.

3-11.1.5 Maintenance Allocation Chart (MAC) is in TM 55-1930-209-14&P-18. For maintenance of other equipment onboard. consult appropriate manual.

3-11.2 Maintenance procedures. Maintenance Instructions are contained in the following paragraphs: Appendix C, Preventive maintenance checks and services: paragraph 3-13, Troubleshooting; and paragraph 3-14, Maintenance procedures.

3-12 Preventive maintenance checks and services. See TM 55-1930-209-14&P-10, Appendix C for preventive maintenance checks and services for the lighting system. See TM 55-1930-209-1 4&P-1 9 for complete preventive maintenance checks and services for all systems on the ROWPU Barge.

3-13 Troubleshooting. Troubleshoot normal exterior lighting system as given in Table 3-2.

3-14 Maintenance procedures.

3-14.1 General. In addition to preventive maintenance, maintenance also involves cleaning and replacing burned-out bulbs.

3-14.2 Cleaning and replacing bulbs. Clean light exteriors with fresh water and soft material or sponge. Do not use chemicals or abrasives that may damage lights.

Table 3-2. Exterior Lighting System Troubleshooting

<u>Condition</u>	<u>Possible Cause</u>	<u>Suggested Action</u>
1. Bow and four port exterior lights do not come on when rotary switch is turned on	a. Circuit breaker P13 on switchboard open	a. Close circuit breaker
	b. Circuit breaker 1 P13 on power panel 3 open	b. Close circuit breaker
c. Rotary on/off switch not	c. Check switch operating normally	
	d. Faulty circuits	d. Check circuit
	e. Bulb(s) burned out	e. Replace bulb(s)
2. Aft and starboard exterior lights do not come on when rotary is switch turned on	Same as a thru e in problem 1	Same as a thru e in problem 1
3. Bow floodlight does not come on when rotary switch is turned on	Same as a thru e In problem 1	Same as a thru e in problem 1
4. Stern floodlights do not come on when rotary switch is turned on	Same as a thru e in problem 1	Same as a thru e in problem 1
5. Forward searchlight on port-a side does not come on when rotary switch is turned on	Circuit breaker 2P13 on power panel 3 open	a. Close circuit breaker
	b. Circuit breaker P13 on switchboard open	b. Close circuit breaker
	c. Rotary switch not operating normally	c. Check switch
	d. Bulb burned out	d. Replace bulb
	e. Faulty circuits	e. Check circuits
6. Aft searchlight on starboard side does not come on when rotary switch is turned on	Same as a thru e in problem 5	Same as a thru e in problem 5
7. Shore discharge hose deployment red and white status lights do not come on when circuit breaker 5P14 on 24 Vdc power panel is closed	Plugs on top of deckhouse not plugged in	a. Insert plugs into receptacles
	b. Bulb(s) burned out	b. Replace bulb(s)
	c. Faulty circuits	c. Check circuits
	d. Emergency electrical system malfunctioning(d. Troubleshoot TM 55-1930-209-14 &P-9)

Table 3-2. Exterior Lighting System Troubleshooting (Continued)

Condition	Possible Cause	Suggested Action
8 Anchor light does not come on when circuit breaker 7P14 on 24 Vdc power panel is closed	<ul style="list-style-type: none"> a. Bulb burned out b. Faulty circuits c. Emergency electrical system malfunctioning 	<ul style="list-style-type: none"> a. Replace bulb b. Check circuits c. Troubleshoot (TM 55-1930-209-14 &P-9)
9. Navigation running lights (starboardside green light, portside red light, or white stern light) do not come on when circuit breaker 2P14 is closed	<ul style="list-style-type: none"> a. Bulb(s) burned out b. Faulty circuits c. Emergency electrical system malfunctioning(<ul style="list-style-type: none"> a. Replace bulb(s) b. Check circuits c. Troubleshoot TM 55-1930-209-14 &P-9)

3-14.2.1 Exterior side lights

- a Turn exterior side lights OFF at rotary switches.
- b Redtag appropriate rotary switch with: "WARNING - DO NOT ACTIVATE - REPAIRS BEING MADE."
- c Remove guard over exterior side light. Remove and clean globe with warm soapy water, rinse, and dry.
- d Replace burned-out bulb.
- e Reinstall globe, making sure gasket is seated properly; reinstall guard.
- f Turn light ON to make sure bulb works.
- g Remove red tag.

3-14.2.2 Floodlights

- a Turn floodlights OFF at rotary switches.
- b Redtag appropriate rotary switch with: "WARNING - DO NOT ACTIVATE - REPAIRS BEING MADE".
- c Remove cover. Clean inside reflector and lens with fresh water. Wipe dry and polish.
- d Replace burned-out bulb.
- e Turn light ON to make sure bulb works.
- f Remove red tag.

3-14.2.3 Searchlights

- a Turn searchlights OFF at rotary switch on searchlight base.
- b Redtag appropriate rotary switch with: "WARNING - DO NOT ACTIVATE - REPAIRS BEING MADE."
- c Open three quick-release latches and open front door of searchlight.
- d Remove burned-out bulb.
- e Clean reflecting mirror and inside of lens with fresh water Wipe dry and polish.
- f Install new bulb, close door, and secure quick-release latches.
- g Turn light ON to make sure bulb works.
- h Remove red tag.

3-14.2.4 Shore discharge hose deployment status lights

- a Open (OFF) circuit breaker 5P14 on 24 Vdc power panel to turn off status lights.
- b Redtag appropriate circuit breaker with: "WARNING - DO NOT ACTIVATE - REPAIRS BEING MADE."
- c Unplug status light at topdeck and lower mast.
- d Loosen cover set screw Turn cover by hand counterclockwise and lift off. Clean with fresh water and wipe dry.
- e Replace burned-out bulb.
- f Reinstall cover, turn clockwise, and tighten set screw.
- g Raise mast and plug light cord into receptacle.
- h Close (ON) circuit breaker 5P14 to make sure bulb works.
- i Remove red tag.

3-14.2.5 Anchor light

- a Open (OFF) circuit breaker 7P14 on 24 Vdc power panel to turn off anchor lights.
- b Redtag circuit breaker with: "WARNING - DO NOT ACTIVATE - REPAIRS BEING MADE."
- c Remove anchor light cover. Clean with fresh water and wipe dry.
- d Replace burned-out bulb.
- e Reinstall light cover.
- f Close (ON) circuit breaker 7P14 to make sure bulb works.
- g Remove red tag.

3-14.2.6 Navigation lights

- a Open (OFF) circuit breaker 2P14 on 24 Vdc power panel to turn off navigation lights.
- b Redtag circuit breaker with: "WARNING - DO NOT ACTIVATE - REPAIRS BEING MADE."
- c Remove navigation light cover. Clean with fresh water. Wipe dry.
- d Replace burned-out bulb.
- e Reinstall light cover.
- f Close (ON) circuit breaker 2P14 to make sure bulb works.
- g Remove red tag.

Section V. Storage

3-15 Short-term storage. If barge is taken out of service for more than 7 days but less than 30 days, and exterior lighting system will not be used while in storage, follow shutdown procedures in paragraph 3-10 Check for corrosion, damage, and pilferage Correct as necessary.

3-16 Administrative storage. If barge is taken out of service for more than 30 days but less than 6 months, barge remains a unit responsibility and shall be maintained by unit personnel. Check for corrosion, damage, and pilferage. Correct as necessary

3-17 Long-term storage. If barge is to be taken out of service for 6 months or more, turn it in to depot for preparation and placement into long-term storage. If barge is In administrative storage and is to be taken out of service and placed In depot long-term storage (6 months or more), process exterior lighting system for normal operations as specified In the following steps before releasing to depot.

- a. Perform before operation checks in Appendix C.
- b. Check that exterior lighting system operates satisfactorily while performing the procedures in paragraphs 3-9 and 3-10.
- c. Perform during operation checks in Appendix C.

CHAPTER 4 EMERGENCY SHUTDOWN

4-1 General. The barge has two emergency shutdown modes. One mode shuts down individual systems such as the ventilation system or a diesel high-pressure pump and the other shuts down all barge operating systems.

Both systems are operated by pushing a red button protected by a metal guard. On system shutdowns, either fuel or electrical power is shut off to that system only. On total shutdown, all fuel and electrical power is shut off to all operating systems and the lighting system. Any system emergency shutdown that stops a generator supplying power to the switchboard also turns off the lighting system.

When the lighting system is off because of an emergency shutdown situation, emergency interior lighting is provided by the 24 Vdc battery bank (paragraph 2-9.2). Exterior lighting requirements are provided automatically from the 24 Vdc battery bank to the shore discharge hose deployment status lights, the anchor light, and the navigation running lights when these lights are turned ON at the 24 Vdc power panel.

4-1/(4-2 blank)

CHAPTER 5 MANUFACTURERS' SERVICE MANUALS/INSTRUCTIONS

5-1 General. The manufacturer's service manuals/instructions listed below provide additional information on the exterior lighting system. A copy of each manual/instruction is contained in Appendix B. It may be necessary to refer to both manuals/instructions and drawings listed in Appendix A, while performing the procedures in this TM.

<u>Component</u>	<u>Document title</u>	<u>Manufacturer</u>
Status lights	Mounting Instructions Type AQUA SIGNAL 70/70D (single optic/double optic)	Aqua Signal Von-Thunen-Str. 12 Postfach 448540 D-2800 Bremen 44 West Germany Supplier: W.H. Swann 1830 Azalea Garden Rd. Norfolk, VA 23320 (804) 855-4711
Exterior lights	Outline Dwg F30208 Watertight Lighting Fixture J1-16, Type J Cable Bushings Replacement Interiors J1-17, Accessories, Adapters for Conduit and Fittings J1-18, Accessories, Adapters and Accessory Parts for Type J Devices	Midland Ross 530 W. Mt. Pleasant Ave. Livingston, NJ 07039 (201) 992-8400
Searchlight	883-2 Searchlight Drawing	Perko, Inc. 16490 N.W. 13th Ave. Miami, FL 33164 (305) 621-7525
Stern light	Figure No. 1127-1130 "A" Series	Perko, Inc. 16490 N.W. 13th Ave. Miami, FL 33164 (305) 621-7525

CHAPTER 6 MANUFACTURERS' WARRANTIES/GUARANTEES

6-1 General. Information on exterior lighting system equipment warranties/guarantees is listed below.

<u>Component</u>	<u>Manufacturer</u>	<u>Duration</u>	<u>Coverage</u>
Status lights	Aqua Signal Von-Thunen-Str. 12 Postfach 448540 D-2800 Bremen 44 West Germany	5 years	Materials and workmanship
Exterior lights	Midland Ross 530 W Mt Pleasant Ave Livingston, NJ 07039 (201) 992-8400	12 months from shipment date	Materials and workmanship
Searchlight	Perko, Inc. 16490 N.W 13th Ave Miami, FL 33164 (305) 621-7525	1 year	Materials and workmanship
Stern light	Perko, Inc. 16490 N.W 13th Ave Miami, FL 33164 (305) 621-7525	1 year	Materials and workmanship

6-1/(6-2 blank)

APPENDIX A

REFERENCES

A-1 Drawings

US Army Belvoir Research, Development and Engineering Center (97403)

- 13226E1892 ROWPU/Barge Arrangement
- 13226E1893 List of Label Plates
- 13226E1932 Electrical Power Schematic Diagram
- 13226E1933 Communication System
- 13226E1934 Load, Cables, and Circuit Breakers Data
- 13226E1935 Electrical Power System Layout
- 13226E1937 Lighting System
- 13226E1938 Emergency Electrical Power/Lighting System
- 13226E1940 Navigation/Exterior Lighting

A-2 Painting

TB 43-0144 Painting of Vessels

A-3 Demolition to Prevent Enemy Use

TM 750-244-3 Procedures for Destruction of Equipment to Prevent Enemy Use

A-4 Maintenance

DA PAM 738-750 The Army Maintenance Management System (TAMMS)

A-1/(A-2 blank)

APPENDIX B

MANUFACTURERS' SERVICE MANUALS/INSTRUCTIONS

<u>Component</u>	<u>Document title</u>	<u>Manufacturer</u>
Status lights	Mounting Instructions Type AQUA SIGNAL 70/70D (single optic/double optic)	Aqua Signal Von-Thunen-Str 12 Postfach 448540 D-2800 Bremen 44 West Germany
Supplier:		W.H. Swann 1830 Azalea Garden
Rd.		Norfolk, VA 23320 (804) 855-4711
Exterior lights	Outline Dwg F30208 Watertight Lighting	Midland Ross 530 W Mt. Pleasant
Ave	Fixture	Livingston, NJ 07039 (201) 992-8400
	J1-16, Type J Cable Bushings Replacement Interiors	
	J1-17 Accessories, Adapters for Conduit and Fittings	
	J1-18, Accessories. Adapters and Accessory Parts for Type J Devices	
Searchlight	883-2 Searchlight Drawing	Perko Inc. 16490 N.W. 13th Ave. Miami, FL 33164 (305) 621-7525
Stern light	Figure No. 1127-1130 "A" Series	Perko, Inc. 16490 N.W. 13th Ave. Miami, FL 33164 (305) 621-7525

B-1/(B-2 blank)

APPENDIX C

Preventive maintenance checks and services (PMCS) for the Lighting System

C-1 Introduction to PMCS

NOTE

TM 55-1930-209-14&P-19 contains PMCS for all systems on the ROWPU Barge. This appendix contains only PMCS for the Lighting System

a. General.

- (1) Systematic (B) before, (D) during, (A) after, and scheduled periodic PMCS are essential to ensure that the Reverse Osmosis Water Purification Barge is in operational readiness at all times. The purpose of the PMCS program is to discover and correct deficiencies and malfunctions before they cause serious damage or failure of the barge and their support systems. An effective PMCS program requires that operators report all unusual conditions noticed before, during and after operation as well as while performing periodic PMCS. All deficiencies and malfunctions discovered during maintenance inspections must be recorded, together with the corrective action taken, on DA Form 2404 (Equipment Inspection and Maintenance Worksheet).
- (2) A schedule for preventive maintenance inspections and service should be established and adhered to. When operating under unusual conditions, such as extreme heat or cold, it may be necessary to perform PMCS more frequently.
- (3) The PMCS items have been arranged and numbered in a logical sequence to provide for greater efficiency and the least amount of downtime required for maintenance.

b. PMCS columnar entries.

- (1) Item Number Column. Checks and services are numbered in chronological order regardless of interval. This column is used as a source of item numbers for the "Item Number" column on DA Form 2404, Equipment Inspection and Maintenance Worksheet, in recording results of PMCS.
- (2) Interval Column. The interval columns tell you when to do a certain check or service: before, during, or after operation. Sometimes a dot may be placed in more than one interval column which would mean you should do the check or service at each of those intervals.
- (3) Item to Be Inspected Column. This column lists the common name of the item to be inspected such as "Air Filters." (4) Procedures Column. This column tells you how to do the required checks and services. Carefully follow these instructions.
- (5) Equipment is Not Ready/Available if Column. This column tells you when and why your equipment cannot be used.

NOTE

The terms "Ready/Available" and "Mission Capable" refer to the same status: equipment is on hand and is able to perform its combat missions. (See DA PAM 738750).

- (6) Increased Inspections. Perform weekly as well as Before Operations PMCS if:
 - (a) You are the assigned operator and have not operated the item since the last weekly PMCS.
 - (b) You are operating the item for the first time.
- (7) Leakage definitions. In checking for fluid leaks, the following leakage definitions apply to all ROWPU - barges and barge equipment, product water, and seawater leakage by class type.
 - (a) Class I - Seepage of fluid (as indicated by wetness or discoloration) not great enough to form drops.
 - (b) Class II - Leakage of fluid great enough to form drops, but not enough to cause drops to drip from the item being checked/inspected.
 - (c) Class III - Leakage of fluid great enough to form drops that fall from the item being checked/inspected.

CAUTION

Equipment operation is allowable with minor leakages (Class I or II). However, the fluid level or operating pressure of the item being checked/inspected must be considered. When in doubt, notify the shift leader or bargemaster.

When operating with Class I or Class II leaks, continue to check fluid levels as required by PMCS and operating instructions.

- (8) The following fuel and hazardous material leakage procedures apply for any fuel, chemical, or bilge system.

WARNING

Class I, II or III leaks or seepage occurring in a fuel, chemical, or bilge container, tank, line, piping, or valve can cause fire or health hazards.

- (a) If any leaks or seepage from a fuel, chemical, or bilge container, tank, or fluid line is detected, it must be immediately reported to the shift leader or bargemaster for corrective action.
- (b) To prevent combustible or toxic fumes from collecting or contaminated material from spilling, exercise extreme caution after detecting leaks or seepage of flammable or hazardous material.
- c. Continuous operation. When equipment must be kept in continuous operation for extended periods of time, check and service only those items that can be checked and serviced without disturbing operations. Perform complete checks and services when the equipment can be shut down.
- d. Maintenance log. Always record the time and date of PMCS, any deficiencies noted, and corrective action taken in the PMCS log book.

C-2 Major components. The lighting system consists of normal and emergency interior lighting and exterior searchlights and floodlights. Major components, their basic functions and location on the barge are listed in Chapter 1.

C-3 Interior Lighting System Description. The interior lighting system provides both normal and emergency lighting in the deckhouse ROWPU space, dayroom, workshop, and voids. The normal lighting system is illustrated in Chapter 1. Power is provided by the service generator, auxiliary generator, or shore power. ROWPU space and void lights are operated from their corresponding lighting panels by closing circuit breakers. Dayroom and workshop lights are operated and controlled from bulkhead-mounted rotary switches. The ROWPU space port and starboard doors and dayroom door to the weatherdeck are each equipped with an interlocking switch that automatically turns off these lights when one of these doors is opened.

In the event of normal power loss, an inverter automatically converts 24 Vdc battery bank power to 120 Vac power. This power is supplied to the emergency panel for emergency lighting and for communications.

Emergency lighting consists of) fluorescent and red incandescent lights and communications power consists of marine radio and telephone system. A green lamp (Barge 1) or blue lamp (Barges 2 and 3), located on the forward panel of the switchboard, indicates that emergency power from the battery bank is available. An emergency light switch is located on the switchboard and next to each door to the weatherdeck so that emergency lights can be readily turned off.

Table C-1. Preventive Maintenance Checks and Services for Lighting System

B - Before
D - During
A - After

D - Daily
W - Weekly
M - Monthly

Q - Quarterly
S - Semiannually
A - Annually

Item No.	Interval										Item to be Inspected	Procedures: Check for and have repaired or adjusted as necessary	Equipment Is Not Ready/ Available If:
	B	D	A	D	W	M	Q	S	A				
1											LIGHTING SYSTEMS Interior Lighting System	<p style="text-align: center;">WARNING</p> Be sure that electrical power is OFF before performing any maintenance on electrical systems. Redtag appropriate switches and circuit breakers with: "WARNING - DO NOT ACTIVATE. REPAIRS BEING MADE. " a. Check for damaged, loose, or frayed cables and loose connections. Repair, replace or tighten as necessary. b. Check for loose or missing securements and fasteners. Tighten and replace as necessary. c. Clean lighting panels and switches with dry, lint-free cloth or vacuum cleaner. d. Check for burned out bulbs. Replace as necessary. e. Remove rust and corrosion. Touch up paint in accordance with TB 43-0144 as necessary. Do not paint threads or labels.	Cables damaged, loose or frayed. Connections loose.

Table C-1. Preventive Maintenance Checks and Services for Lighting System (Continued)-

B - Before
D - During
A - After

D - Daily
W - Weekly
M - Monthly

Q - Quarterly
S - Semiannually
A - Annually

Item No.	Interval										Item to be Inspected	Procedures: Check for and have repaired or adjusted as necessary	Equipment Is Not Ready/ Available If:
	B	D	A	D	W	M	Q	S	A				
2											Exterior Lighting System	<p>WARNING Be sure that electrical power is OFF before performing any maintenance on electrical systems. Redtag appropriate switches and circuit breakers with: "WARNING - DO NOT ACTIVATE. REPAIRS BEING MADE. " Observe all safety precautions listed at the beginning of this manual.</p> <p>a. Check for damaged, loose, or frayed cables, and loose connections. Repair, replace or tighten as necessary.</p> <p>b. Check for loose or missing fasteners and securements. Tighten and replace as necessary.</p> <p>c. Clean lighting panels and switches with a dry, lint-free cloth or with a vacuum cleaner. Remove rust and corrosion. Touch up paint in accordance with TB 43-0144 as necessary. Do not paint threads and labels.</p> <p>d. Check for burned-out exterior side lights. Replace as follows: 1) Turn exterior side lights OFF at rotary switches. 2) Redtag appropriate switch with: "WARNING - DO NOT ACTIVATE. REPAIRS BEING MADE. " 3) Remove light guard. Remove and clean globe with warm, soapy water, rinse and dry. 4) Replace burned-out bulb. 5) Reinstall glove, making sure gasket is properly seated; reinstall guard. 6) Check to see new light works. 7) Remove redtag.</p> <p>e. Check for burned-out floodlights. Replace as follows: 1) Turn floodlights OFF at rotary switches.</p>	<p>Cables damaged, loose or frayed. Connections loose.</p> <p>Side lights inoperable.</p> <p>Floodlights inoperable.</p>

Table C-1. Preventive Maintenance Checks and Services for Lighting System (Continued)-

B - Before
D - During
A - After

D - Daily
W - Weekly
M - Monthly

Q - Quarterly
S - Semiannually
A - Annually

Item No.	Interval										Item to be Inspected	Procedures: Check for and have repaired or adjusted as necessary	Equipment Is Not Ready/ Available If:
	B	D	A	D	W	M	Q	S	A				
												<ul style="list-style-type: none"> 2) Redtag appropriate rotary switch with: "WARNING - DO NOT ACTIVATE. REPAIRS BEING MADE. " 3) Remove cover. Clean inside reflector and lens with fresh water. Wipe dry and polish. 4) Replace burned-out bulb. 5) Check to see new light works. 6) Remove redtag. 	
		•										<ul style="list-style-type: none"> f. Check for burned-out searchlights. Replace as follows: <ul style="list-style-type: none"> 1) Turn searchlights OFF at rotary switch on searchlight base. 2) Redtag appropriate rotary switch with: "WARNING - DO NOT ACTIVATE. REPAIRS BEING MADE. " 3) Open three quick-release latches to open front door of searchlight. 4) Remove burned-out bulb. 5) Clean reflecting mirror and inside of lens with fresh water. Wipe dry and polish. 6) Install new bulb, close door and secure quick-release latches. 7) Check to see new light works. 8) Remove redtag. 	Searchlights inoperable.
												<ul style="list-style-type: none"> g. Check for burned-out shore discharge hose deployment status lights. Replace as follows: <ul style="list-style-type: none"> 1) Open (OFF) circuit breaker 5P14 on 24 Vdc power panel to turn off status lights. 2) Redtag appropriate circuit breaker with: "WARNING - DO NOT ACTIVATE. REPAIRS BEING MADE. " 3) Unplug status light at topdeck and lower mast. 4) Loosen cover set screw. Turn cover by hand counterclockwise and lift off. Clean with fresh water and wipe dry. 	Status lights inoperable.

B - Before
D - During
A - After

D - Daily
W - Weekly
M - Monthly

Q - Quarterly
S - Semiannually
A - Annually

Item No.	Interval										Item to be Inspected	Procedures: Check for and have repaired or adjusted as necessary	Equipment Is Not Ready/ Available If:
	B	D	A	D	W	M	Q	S	A				
												5) Replace burned-out bulb. 6) Reinstall cover, turn counterclockwise, and tighten set screw. 7) Raise mast and plug light cord into receptacle. 8) Check to see new light works. 9) Remove redtag.	
		•		•		•						h. Check anchor light for burned-out bulbs. Replace as follows: 1) Open (OFF) circuit breaker 7P14 on 24 Vdc power panel to turn off anchor lights. 2) Redtag appropriate circuit breaker with: WARNING - DO NOT ACTIVATE. REPAIRS BEING MADE. " 3) Remove anchor light cover. Clean with fresh water and wipe dry. 4) Replace burned-out bulb. 5) Reinstall light cover. 6) Check to see new light works. 7) Remove redtag.	Anchor light inoperable.
		•		•		•						i. Check navigation lights for burned-out bulbs. Replace as follows: 1) Open (OFF) circuit breaker 2P14 on 24 Vdc power panel to turn off navigation lights. 2) Redtag appropriate circuit breaker with: "WARNING - DO NOT ACTIVATE. REPAIRS BEING MADE. " 3) Remove navigation light cover. Clean with fresh water. Wipe dry. 4) Replace burned-out bulb. 5) Reinstall light cover. 6) Close (ON) circuit breaker 2P14 to make sure bulb works. 7) Remove redtag.	Navigation lights inoperable.

Mounting Instructions

Type AQUA SIGNAL 70/70 D (single optic/double optic)

These Navigation lights comply with national and international regulations regarding minimum visibility, luminous intensity of horizontal and vertical sectors and color specifications for all vessels of 20 meters or more in length (IMCO 1972).

Lights carrying an α besides the DHI-symbol may be utilized on German inland waterways.

However, their correct function may be guaranteed only if special attention is paid to certain points regarding mounting and servicing. It is therefore essential to read the following pages cautiously and to follow the mounting instructions in the same way.

Important:

The upper part of the lantern with double optic is always to be used for the main-lightning and the lower part for the spare-lightning.

Regulations

For foreign ships Annex I - Positioning and Technical Details of Lights and Shapes - of the new Collision Regulations, 1972, are to be applied.

The technical data, regarding horizontal and vertical positioning and spacing of the navigation lights, laid down in these mounting instructions do apply to all ships, no matter what nationality they are.

Side lights AQUA SIGNAL 70

No. of approval: DHI/01/05/75 (Deutsches Hydrographisches Institut)

Side lights AQUA SIGNAL 70 D

No. of approval: DHI/01/05/1/75

Horizontal sector 11 2, 5"

Visibility 3 nautical miles

The Side lights must be mounted in such a way that the horizontal plane A of the light is parallel to the CWL (pict. 1).

Special attention is to be paid to the right ahead direction. It is important that the measurement α , X" shown in pict. 2 and table 2. 1 is always correct. If it is too small, the light intensity in the right ahead direction may be reduced.

Masthead lights AQUA SIGNAL 70

No. of approval: DHI/O 1/05/75 (Deutsches Hydrographisches Institut)

Masthead lights AQUA SIGNAL 70 D

No. of approval: DHI/01/05/1/75

Horizontal sector 225°

Visibility 6 nautical miles

The Masthead light must be mounted in such a way that the horizontal plane A of the light is parallel to the construction water line (CWL) (pict. 1). For proper mounting see pict. 3.

If more than one Masthead light is to be fitted - annex 1 - of the Collision Regulations 1972 is to be looked at. For vertical and horizontal positioning and spacing of the lights in general see pict. 1.

Stern light AQUA SIGNAL 70

No. of approval: DHI/01 /05/75 (Deutsches Hydrographisches Institut)

Stern light AQUA SIGNAL 70 D

No. of approval: DHI/01 /05/1/75

Horizontal sector 135°

Visibility 3 nautical miles

The Stern light must be mounted in such a way that the horizontal plane A of the light is parallel to the construction water line (CWL) (pict. 1).

The right astern direction is marked on the light as shown on the pict. 4. It should be in and above the keel line. The rear of the light should be aligned thwartships.

For proper mounting see pict. 4.

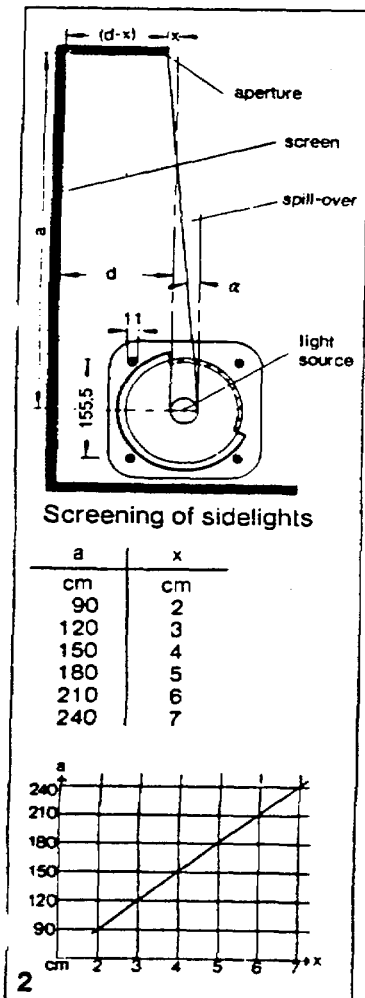

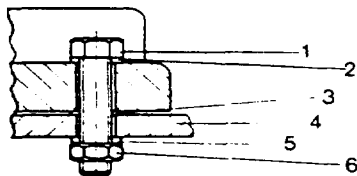
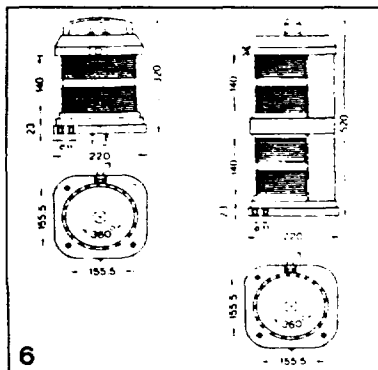
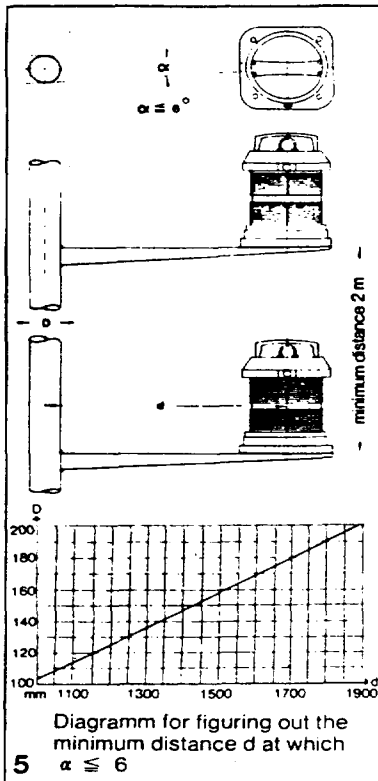

Assembling of screw-set

1. Stain. Steel M 10 x 50
2. Washer 0 10, 5
3. Washer (plastic) 0 10, 5
4. Mounting plate min 8 mm or with appropriate support
5. Lock washer 0 10, 5
6. Nut (stainless) M 10
max. permissible torque
50 Nm (, 5 Kpm)

Signal navigation lights AQUA SIGNAL 70

No. of approval: DHI/01/06/75 (Deutsches Hydrographisches Institut)

Signal navigation lights AQUA SIGNAL 70 D

No. of approval: DHI/01/06/1/75

Horizontal sector 360"

Visibility 3 nautical miles

Signal navigation lights may be fixed mounted or hoisted. In case they are fixed to the ship it is important that their horizontal arc of light is not obstructed by parts of the ship or mast. Unavoidable obstructions should be within an arc of 6° (pict. 5).

Wiring

All navigation lanterns AQUA SIGNAL 70, except the signaling lights for hoisting, are fitted with a cable 1,5 m long (type: H07RN-F3G 1,5; 3 x 1,5 mm 0, oil and water resistant).

The lanterns AQUA SIGNAL 70 D are fitted with two cables.

Alternatively they may also be supplied with standardized plugs according to DIN 89267 (11 Oie. 220 V).

In case it is necessary to renew the cable of a AQUA SIGNAL 70, the socket holder is to be unscrewed (3 screws) and may be pulled out through the top. Situated on its back is the terminal board with ground attachment.

To renew the cables of a AQUA SIGNAL 70 D, it is necessary to remove the upper socket mounting plate first. Now the upper cable can be changed. The lower cable can be renewed as mentioned above.

Bulb and bulb change

There are 3 different bulbs in 24, 110 and 220 V. They have a socket P 28 and may therefore put in only in one defined position.

To change the bulb it is necessary to disconnect the plug first, to loosen the safety screw, then turn the cover by its handle to the left and lift up the cover. The bulb may then be changed from the top.

To change the lower bulb in the AQUA SIGNAL 70 D, it is necessary to remove the upper socket mounting plate.

Service

All parts of the navigation lanterns are made of sea water resistant materials a, do not need any special attention. Cleaning of the outside every now and then may be of some use. It should be carried out only with fresh water and soft materials or sponge. Acid chemicals or other abrasive cleaning materials must not be used, especially not on the lens.

Important

Due to light specific reasons no paint or any other anticorrosives should be applied to the lantern.

ERSATZTEILE/*ZUBEH•R
SPARE PARTS/*ACCESSORIES
PIECES DETACHEES/*ACCESSORIES

AQUA SIGNAL 70 (einlinsig/single optic/simple optique)

63074-001
 Backbord/Port/
 Båbord

63073-001
 Steuerbord/Starbord/
 Tribord

63072-001
 Heck/Stern/Pompe

63071-001
 Topp/Masthead/
 Tete de mât

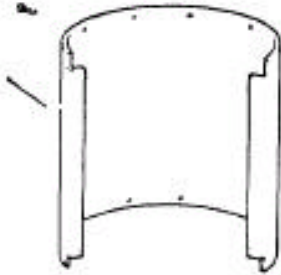

83070-003

Deckel komplett für Signallaternen/
 Cover complete for allround lights/
 Couverde cpl. pour des feux signalisation

83071-001

Deckel komplett für Seiten-, Topp- und Hecklaternen/
 Cover complete for side-, masthead- and stern lights
 Couverde cpl. pour des feux de navigation



958-00146

83070-004 weiß/white/opale

83070-005 grün/green/vert

83070-006 rot/red/rouge

83070-007 gelb/yellow/jaune

*Konzentrischer Stecker/Concentric
 lug/fiche concentrique 24 V)
72-00035

*HNA-Stecker/
 Standard Marine plug/
 fiche bi-polaire

971-00034
 220 V Messing/brass/laiton

971-00035
 220 V Kunststoff/plastic/plastique

971-00036
 110 V Messing/brass/laiton

971-00037
 110 V Kunststoff/plastic/plastique

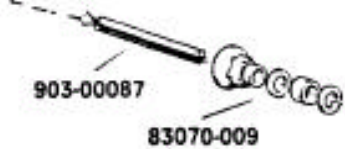

903-00087

83070-009

904-00171 24 V / 40 W

904-00172 110 V / 60 W

904-00173 220 V / 85 W

83070-008

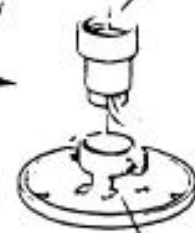

83070-002

***83070-001**

Schrauben-Satz/
 Fastening bolts + nuts, set/
 jeu de vis
 (4 Stck./4 pieces/4 pièces)

***33906-001** 2 Tauösen/halyard hooks/oeillet de cordage

63074-001

Backbord/Port/
Båbord

63073-001

Steuerbord/Starbord/
Tribord

63072-001

Heck/Stern/Ponpe

63071-001

Topp/Masthead/
Tête de mât

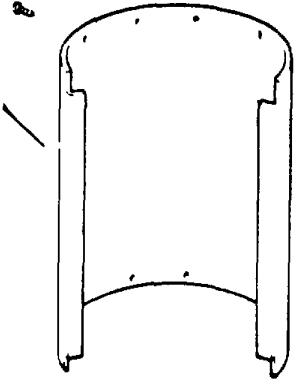

83070-003

Deckel komplett für Signallaternen/
Cover complete for allround lights/
Couverde cpl. pour des feux signalisation

83071-001

Deckel komplett für Seiten-, Topp- und Hecklaternen/
Cover complete for side-, masthead- and stern lights
Couverde cpl. pour des feux de navigation

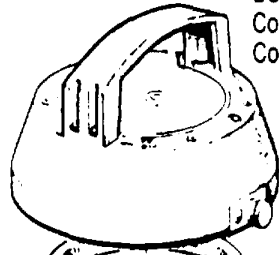

958-00146

*Konzentrischer Stecker/Concentric
plug/fiche concentrique 24 V)

972-00035



*HNA-Stecker/
Standard Marine plug/
fiche bi-polaire

971-00034

220 V Messing/brass/laiton

971-00035

220 V Kunststoff/plastic/plastique

971-00036

110 V Messing/brass/laiton

971-00037

110 V Kunststoff/plastic/plastique

83070-004 weiß/white/opale

83070-005 grün/green/vert

83070-006 rot/red/rouge

83070-007 gelb/yellow/jaune

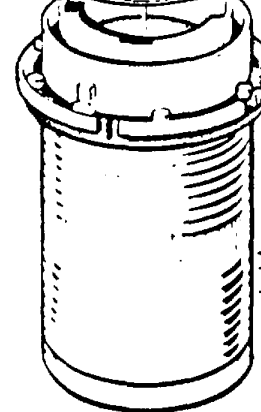

904-00171 24 V / 40 W

904-00172 110 V / 60 W

904-00173 220 V / 65 W

83070-008

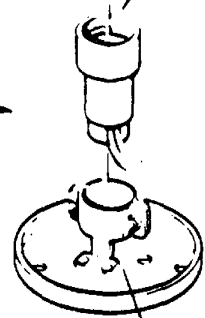
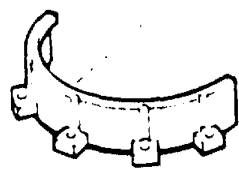

83070-002

903-00087

83070-009

*83070-001

Schrauben-Satz/
Fastening bolts + nuts, set/
jeu de vis
(4 Stck./4 pieces/4 pièces)

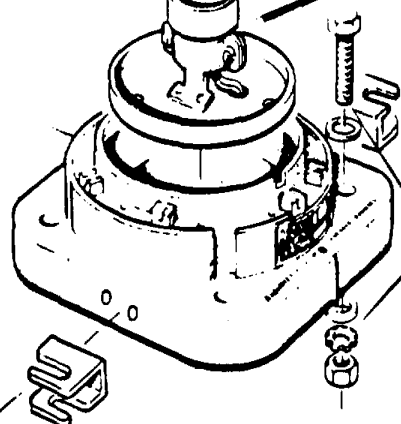

*33906-001 2 Tauoesen/halyard hooks/oeillet de cordage

AQUA SIGNAL CONTROL

Elektronische Schalt- und Überwachungspaneele für Positionslaternen aqua signal-Control arbeitet voll elektronisch und ist zum Teil mit integrierten Schaltkreisen aufgebaut. Die Bereinigung der Spannungsversorgung und die Messungen sind auf verschiedenen Karten untergebracht. aqua signal-Control enthält keine beweglichen, mechanischen Teile (Relais etc.). Dadurch keine Geräusentwicklung während des Betriebes. Durch diese Bauweise wird eine außerordentlich hohe Betriebszuverlässigkeit gewährleistet. Die Bedienung dieses Gerätes ist einfach. Durch Öffnen des Hauptschalters werden die Laternenstromkreise und die Fehlerlogik eingeschaltet. Die Leuchten können nun je nach Wahl und Fahrtzustand des Bootes einzeln zu- oder abgeschaltet werden. Ein weiterer Vorteil des Gerätes liegt darin, dass bei gleichbleibendem Fahrtzustand die 4 Laufschalter die betreffenden Laternen insgesamt ein- oder ausgeschaltet werden können.

Double Function Electronic Switch- and Control Panel for Navigation lights

aqua signal-Control works fully electronic and is built with the best electronic components available. The different working unit (power supply, measurements) are placed on different print boards. aqua signal-Control does not have any movable mechanical parts (relays or similar). Therefore no noise whatsoever during operation. Through all this extreme safety of operation is guaranteed.

Operation of the unit is very simple. Turning of master switch puts fault detecting unit and navigation light circuits in operation.

Navigation lights may now be switched individually on or off according to ships movement.

Convenient the fact that groups of lights may be switched on and off by the master switch.

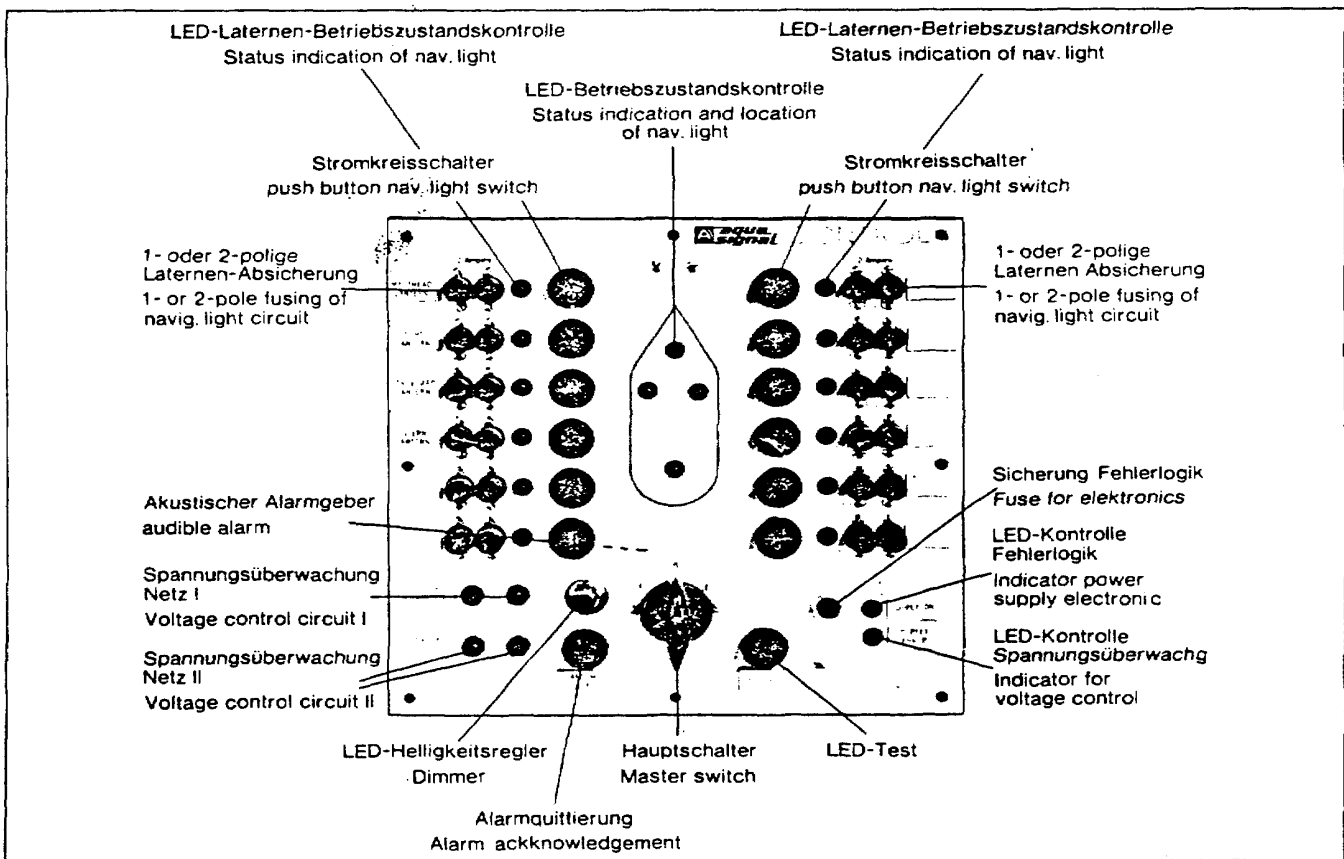

Printed in Germany · Augenzeugen vorbehalten · Simpaq to alternative · Swiss Federal de model, 1985 · 942 00221 01

MIDLANDROSS LIVINGSTON NEW JERSEY 07039	THIS DRAWING IS THE PROPERTY OF E. I. du ROY & CO., INC. IT IS TO BE USED ONLY FOR THE PURPOSE FOR WHICH IT WAS EXPRESSLY LOANED AND IS NOT TO BE USED IN ANY WAY DETRIMENTAL TO THE INTERESTS OF THIS CONCERN.		OUTLINE Dwg F3020E
	ALTERATIONS:		
TITLE WATERTIGHT LIGHTING FIXTURE WALL MTG ~ CAST ALUM. FOR 150 WATT	SCALE 6 REDR. SUPS. #5 (A3092) 7 ADD PLUGS 1/2 - 14 NPT - PLUGS IS 24-12	DATE 11-17-82	
DRN DEH CHK'D _____ APPD _____ APPD _____			

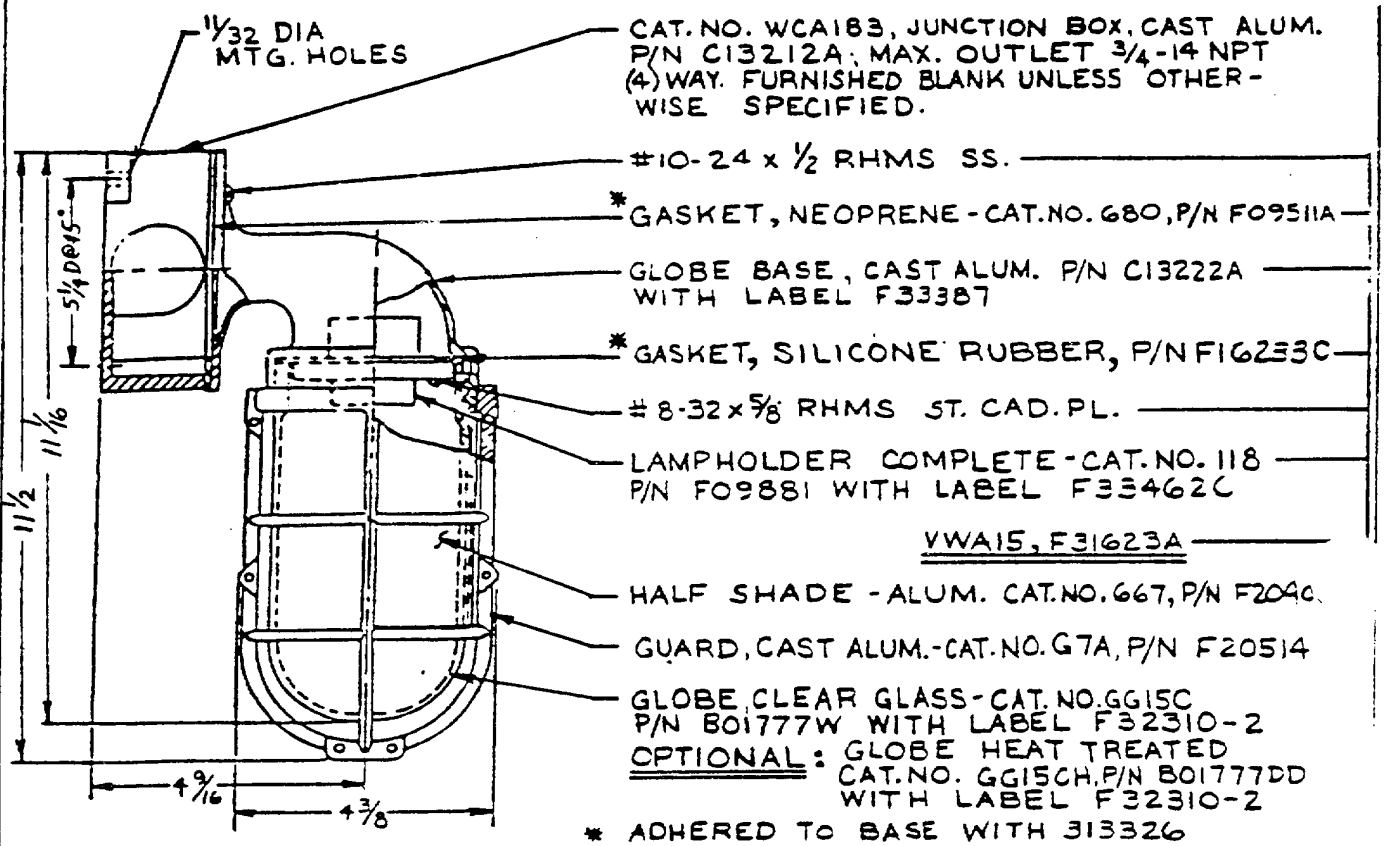

E	A, B, C & D	M	A & C
D	B, C & D	K	A, B, C & D
C	B & C	J	B, C & D
E	B & D	H	B & C
A	B	G	B & D
		F	B
SUFFIX	3/4 - 14 N.P.T.	SUFFIX	1/2 - 14 N.P.T.
FOR CONDUIT OPENINGS ADD SUFFIX TO PART NO. SIZE & LOCATION (C13212 REF.)			
F30208F	LVWA15GHSV	X	X X X X X
F30208E	LVWA15GSV	X	X X X X X
F30208D	LVWA15SV	X	X X X X X
F30208C	LVWA15GH	X	X X X X X
F30208B	LVWA15G	X	X X X X X
F30208A	LVWA15	X	X X X X X
PART NO.	CAT. NO.	VWA15	GG15C G7A 667 VWA15SV WCA183
USED ON		COMPONENT STRUCTURE	

OUTLINE Dwg F. 200

Type J

Cable Bushings
Replacement Interiors

**CABLE BUSHINGS
CATALOG NUMBER AND AMPERE RATING
OF PLUG OR CONNECTOR**

Hole Dia. . for Cable	30 AMP Size 3	60 AMP Size 6	100 AMP Size 10	200 AMP Size 20
3/8-inch	JG31.			
1/2-inch	JG32			
9/16-inch	JG325			
19/32-inch	JG32B,			
5/8-inch	JG33	JG63		
3/4-inch	JG34	JG64	JG104	
25/32-inch	JG341			
7/8-inch	JG35	JG65	JG105	
15/16-inch	JG355			
1-inch	JG38	JG66	JG106	JG206
1-1/8-inch	JG361			
1-3/16-inch		JG67-	JG107	JG207
1-5/16-inch			JG108	JG208
1-3/8-inch		JG69		
1-1/2-inch		JG619	JG1010	JG2010
1-11/16-inch			JG 1011	JG2011
1-13/16-inch				JG2012
1-7/8-inch			JG1013	
2-inch				JG2014
2-1/8-inch				JG2015
2-1/4-inch				JG2016
2-1/2-inch				JG2017

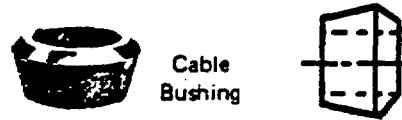

Notes:

Size No. 3 , 6 , 10
and 20

Material — Oil resistant Neoprene.

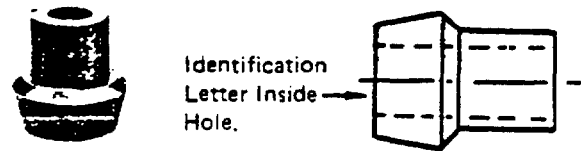

Size No. 3, 6, 10 and 20.

**INTERIOR ASSEMBLIES for Type J
INSULATING BODY COMPLETE WITH CONTACTS**

Description	Ampere Rating			
	30 Catalog No.	60 Catalog No.	100 Catalog No.	200 Catalog No.

Female Interior Assembly for Receptacles and Connectors

*2 wire, 2 pole	JRU322	JRU622	JRU1022	JRU2022
2 wire, 3 pole	JRU323	JRU623	JRU1023	JRU2023
*3 wire, 3 pole	JRU333	JRU633	JRU1033	JRU2033
3 wire, 4 pole	JRU334	JRU634	JRU1034	JRU2034
*4 wire, 4 pole	JRU344	JRU644	JRU1044	JRU2044

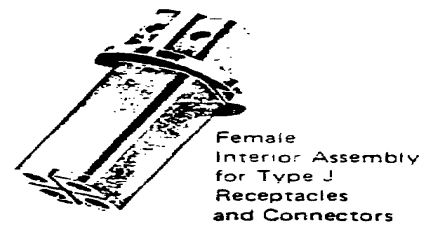

Female Interior Assembly for Type J Receptacles and Connectors

Male Interior Assembly for Plugs

*2 wire, 2 pole	JPU322	JPU622	JPU1022	JPU2022
2 wire, 3 pole	JPU323	JPU623	JPU1023	JPU2023
*3 wire, 3 pole	JPU333	JPU633	JPU1033	JPU2033
3 wire, 4 pole	JPU334	JPU634	JPU1034	JPU2034
*4 wire, 4 pole	JPU344	JPU644	JPU1044	JPU2044

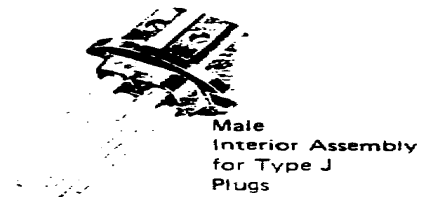

Male Interior Assembly for Type J Plugs

*Includes equipment grounding lug for attachment to enclosure.
Material-Molded composition with silvered copper contacts.

**Adapters for
Conduit and Fittings
For use on Type J Plugs and Connectors
Accessories**

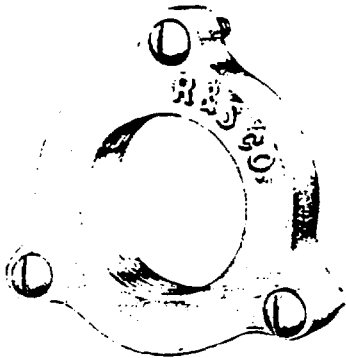

JPA 64

Adapters are tapped NPT standard pipe thread to accommodate rigid conduit or standard connectors for armored and non-metallic cable or flexible conduit.

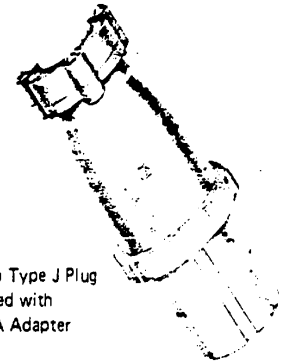

60 Amp Type J Plug
Equipped with
No. JPA Adapter

PLUG OR CONNECTOR SIZES

30 Amp. Catalog No.	Tapped Hole Size NPT	60 Amp. Catalog No.	Tapped Hole Size NPT	100 Amp. Catalog No.	Tapped Hole Size NPT	200 Amp. Catalog No.	Tapped Hole Size NPT
JPA31	1/2"	JPA63	1"	JPA104	1-1/4"	JPA205	1-1/2"
JPA32	3/4"	JPA64	1-1/4"	JPA105	1-1/2"	JPA206	2"
JPA33	1"	JPA65	1-1/2"	JPA106	2"	JPA207	2-1/2"

Notes:

Material - Cast aluminum, corrosion-resistant copper-free alloy, natural finish. Furnished complete with gasket and screws.

When standard plugs or connectors are required to be furnished equipped with one of the above adapters, suffix the catalog number of the adapter selected to the catalog

Cup Caps for Type JPS Plugs

number of the plug or connector. Complete list price is the total of the list price of the device plus the list price of the adapter.

Example: Cat. No. JPS634H with adapter tapped 1-inch would be Cat. No. JPS634H-JPA63.

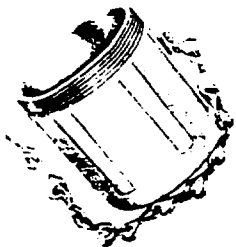

Amperes	Catalog No.
30	F30717A
60	F30718A
100	F30814A
200	F30815A

Cup Caps are used:

- Where portable equipment is on a standby basis and plugs are not in use.
- To effectively protect insulation and contacts from excessive moisture, dirt, dust and corrosion.

Material - cast aluminum, corrosion-resistant copper-free alloy, natural finish, with steel Cadmium Plate Chain.

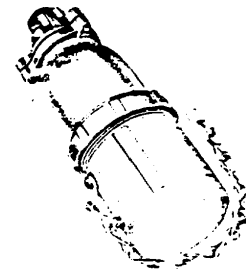

Accessories

**Adapters and Accessory Parts or Type J Devices
Parts for Type J Devices**

Adapter Flush Frames

These adapter flush frames provide suitable means for mounting the box covers of Style JRFA, JRFH, JRPR, JRSA, JRSH and JRSR Junction Box receptacles flush in a wall or panel.

Receptacle Rating Amperes	Single Gang Adapter Flush Frame		Dimensions Overall	
	Catalog No.	Length	Width	
30	JFA3	5-3/8"	4"	
60	JFA6	6-3/8"		5"
100	JFA10	6-5/8"	6-5/8"	
200	JFA20	9-13/16"	9-13/16"	

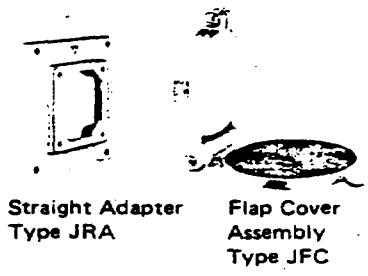

Straight Adapter Type JRA
Flap Cover Assembly Type JFC

Accessory Parts

Type J standard catalog items may be converted to Weathertight or Waterproof or changed in style by the addition or substitution of the appropriate interchangeable parts listed below. Work may be done easily in the field no special tools are required.

Adapters to fit existing boxes and for special mounting requirements can also be furnished. Prices and information on application.

Ampere Rating of Equipment

Description of Accessory Part	30 Catalog No.	60 Catalog No.	100 Catalog No.	200 Catalog No.
Flap Cover Assembly	JFC3	JFC6	JFC10	JFC20
Screw Cap and Chain Assembly	JSC3	JSC6	JSC10	JSC20
Adapters for Conduit Box Receptacles:				
20° Vertical Angle Adapter	JAA3	JAA6-AB6	JAA10	JAA20
45° Vertical Angle Adapter	JAA345	JAA645	JAA10-45	JAA20-45
20° Horizontal Angle Adapter	JHA3	◆	◆	◆
Straight Adapter	JRA3	JRAA-AB6	JRA10	JRA20
▲ For Special Mounting Applications	JAAB3	JAAB6	JAAB 10	JAAB-20
Junction Box-single gang	JB3	JB6	JBO1	JB20
Angle Enclosure	JE3	JE6	Not available	
Screw Collar Nut with Gasket for Plugs	JSN3	JSN6	JSN10	JSN20

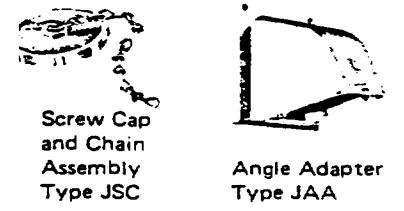

Screw Cap and Chain Assembly Type JSC
Angle Adapter Type JAA

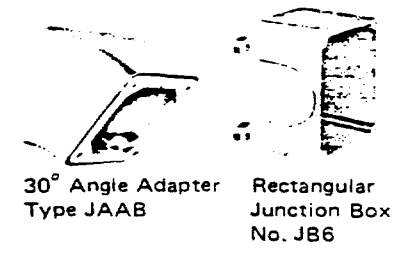

30° Angle Adapter Type JAAB
Rectangular Junction Box No. JB6

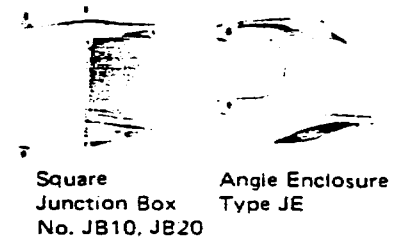

Square Junction Box No. JB10, JB20
Angle Enclosure Type JE

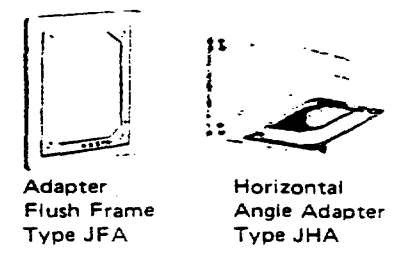

Adapter Flush Frame Type JFA
Horizontal Angle Adapter Type JHA



Screw Collar Nut for Waterproof Plugs Type JSN

Notes:

◆ Available in 30 ampere size only. As 30 ampere junction box is rectangular, Adapter JHA3 is required when box is used in the horizontal position and Adapter JAA3 is required when box is used in the vertical position. 60 ampere adapters are available in the vertical mounting style only. The 60 ampere box is rectangular: 100 and 200 ampere size boxes are square.

▲ Has small size flange. Will not fit standard receptacle box. Material Cast aluminum, corrosion resistant copper free alloy, aluminum finish.

Other metals available prices and information on application. Furnished complete with gaskets and screws. Outlets Unless otherwise specified, regularly furnished with outlets specified for ampere ratings.

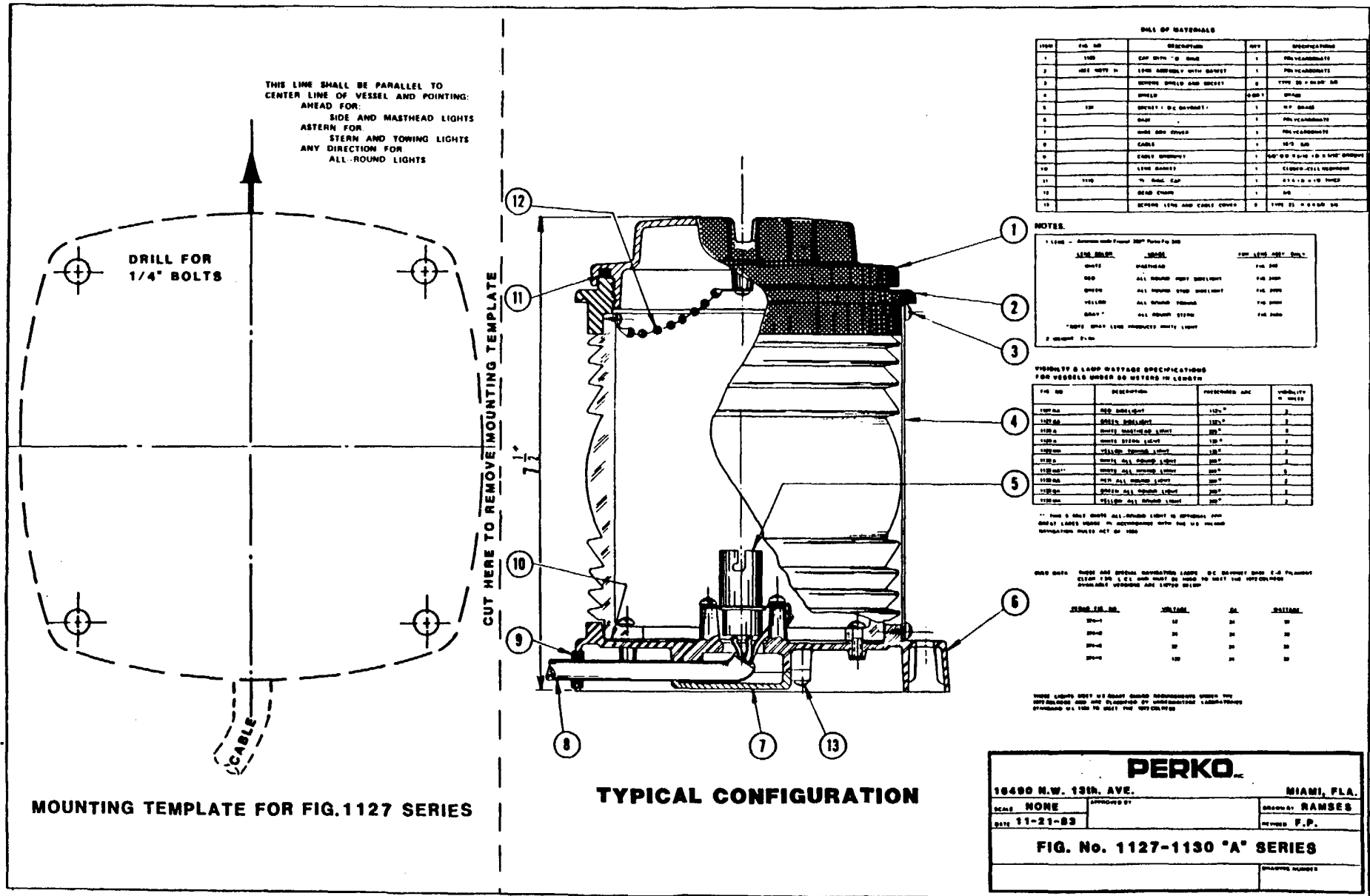

THIS LINE SHALL BE PARALLEL TO CENTER LINE OF VESSEL AND POINTING AHEAD FOR:
 SIDE AND MASTHEAD LIGHTS
 ASTERN FOR
 STERN AND TOWING LIGHTS
 ANY DIRECTION FOR
 ALL-ROUND LIGHTS

DRILL FOR 1/4" BOLTS

CUT HERE TO REMOVE MOUNTING TEMPLATE

MOUNTING TEMPLATE FOR FIG. 1127 SERIES

TYPICAL CONFIGURATION

BILL OF MATERIALS

ITEM	FIG. NO.	DESCRIPTION	QTY.	REMARKS
1	1100	CAP WITH "O" RING	1	POLYCARBONATE
2	ALL NEW	LENS ASSEMBLY WITH GASKET	1	POLYCARBONATE
3		REFLECTOR SHIELD AND GASKET	1	TYPE 21 1/2 X 3/8 IN. SS
4		SHIELD	1	SPRUE
5	100	REFLECTOR "O" RING	1	SP. BRASS
6		GASKET	1	POLYCARBONATE
7		WIRE END COVER	1	POLYCARBONATE
8		CABLE	1	1/2" DIA.
9		COVER BRACKET	1	1/2" X 1/2" X 1/2" S.P. BRASS
10		LENS GASKET	1	CLEAR CELL NEOPRENE
11	1100	"O" RING CAP	1	1/2" X 1/2" X 1/2" S.P. BRASS
12		DEAD END	1	SS
13		REFLECTOR SHIELD AND CABLE COVER	1	TYPE 21 1/2 X 3/8 IN. SS

NOTES.

1. LAMP - American Electric Lamp 300° Beam 700

LENS COLOR	SHIELD	REFLECTOR	TYPE
WHITE	REFLECTOR	REFLECTOR	FIG. 1100
RED	ALL ROUND SHIELD LIGHT	REFLECTOR	FIG. 1100
GREEN	ALL ROUND SHIELD LIGHT	REFLECTOR	FIG. 1100
YELLOW	ALL ROUND SHIELD LIGHT	REFLECTOR	FIG. 1100
ORANGE	ALL ROUND SHIELD LIGHT	REFLECTOR	FIG. 1100

*NOTE: SHIELD LIGHTS IMPROVE NIGHT LIGHT

2. MOUNTING PLATE

PROPOSED LAMP MOUNTING SPECIFICATIONS FOR VESSELS UNDER 20 METERS IN LENGTH

FIG. NO.	DESCRIPTION	POSITIONING AHD	VISIBILITY IN METERS
1100-00	RED SHIELD LIGHT	150"	2
1100-01	GREEN SHIELD LIGHT	150"	2
1100-02	WHITE SHIELD LIGHT	150"	2
1100-03	WHITE SHIELD LIGHT	150"	2
1100-04	YELLOW SHIELD LIGHT	150"	2
1100-05	ORANGE SHIELD LIGHT	150"	2
1100-06	WHITE SHIELD LIGHT	150"	2
1100-07	WHITE SHIELD LIGHT	150"	2
1100-08	WHITE SHIELD LIGHT	150"	2
1100-09	WHITE SHIELD LIGHT	150"	2

** FROM 0 DEGT ABOVE ALL-ROUND LIGHT IS OPERATED FROM 0 DEGT LAMP LIGHT IS ACCOMPANIED WITH THE 1/2" RED LIGHT NAVIGATION RULES SET OF 1950

*** FROM 0 DEGT ABOVE ALL-ROUND LIGHT IS OPERATED FROM 0 DEGT LAMP LIGHT IS ACCOMPANIED WITH THE 1/2" RED LIGHT NAVIGATION RULES SET OF 1950

*** FROM 0 DEGT ABOVE ALL-ROUND LIGHT IS OPERATED FROM 0 DEGT LAMP LIGHT IS ACCOMPANIED WITH THE 1/2" RED LIGHT NAVIGATION RULES SET OF 1950

FIG. NO.	HEIGHT	DIAM.	DISTANCE
1100-01	10	30	30
1100-02	20	30	30
1100-03	30	30	30
1100-04	40	30	30

PERKO
 16400 N.W. 13TH AVE. MIAMI, FLA.
 SCALE: NONE DRAWN BY: RAMSES
 DATE: 11-21-83 CHECKED BY: F.P.
FIG. No. 1127-1130 "A" SERIES

By Order of the Secretary of the Army:

Official:

GORDON R. SULLIVAN
General, United States Army
Chief of Staff

MILTON H. HAMILTON
Administrative Assistant to the
Secretary of the Army
06912

DISTRIBUTION;

To be distributed in accordance with DA Form 12-25E, qty rqr block no. 3634, requirements for TM 55-1930-209-14&P-10.

RECOMMENDED CHANGES TO EQUIPMENT TECHNICAL PUBLICATIONS



SOMETHING WRONG WITH THIS PUBLICATION?

THEN... JOT DOWN THE DOPE ABOUT IT ON THIS FORM, CAREFULLY TEAR IT OUT, FOLD IT AND DROP IT IN THE MAIL!

FROM: (PRINT YOUR UNIT'S COMPLETE ADDRESS)

DATE SENT

PUBLICATION NUMBER

PUBLICATION DATE

PUBLICATION TITLE

BE EXACT... PIN-POINT WHERE IT IS				IN THIS SPACE TELL WHAT IS WRONG AND WHAT SHOULD BE DONE ABOUT IT:
PAGE NO.	PARA-GRAPH	FIGURE NO.	TABLE NO.	

PRINTED NAME, GRADE OR TITLE, AND TELEPHONE NUMBER

SIGN HERE:

TEAR ALONG PERFORATED LINE

DA FORM 2028-2
JUL 79

PREVIOUS EDITIONS ARE OBSOLETE.

P.S.—IF YOUR OUTFIT WANTS TO KNOW ABOUT YOUR RECOMMENDATION MAKE A CARBON COPY OF THIS AND GIVE IT TO YOUR HEADQUARTERS.

The Metric System and Equivalents

Linear Measure

1 centimeter = 10 millimeters = .39 inch
 1 decimeter = 10 centimeters = 3.94 inches
 1 meter = 10 decimeters = 39.37 inches
 1 dekameter = 10 meters = 32.8 feet
 1 hectometer = 10 dekameters = 328.08 feet
 1 kilometer = 10 hectometers = 3,280.8 feet

Weights

1 centigram = 10 milligrams = .15 grain
 1 decigram = 10 centigrams = 1.54 grains
 1 gram = 10 decigrams = .035 ounce
 1 dekagram = 10 grams = .35 ounce
 1 hectogram = 10 dekagrams = 3.52 ounces
 1 kilogram = 10 hectograms = 2.2 pounds
 1 quintal = 100 kilograms = 220.46 pounds
 1 metric ton = 10 quintals = 1.1 short tons

Liquid Measure

1 centiliter = 10 milliliters = .34 fl. ounce
 1 deciliter = 10 centiliters = 3.38 fl. ounces
 1 liter = 10 deciliters = 33.81 fl. ounces
 1 dekaliter = 10 liters = 2.64 gallons
 1 hectoliter = 10 dekaliters = 26.42 gallons
 1 kiloliter = 10 hectoliters = 264.18 gallons

Square Measure

1 sq. centimeter = 100 sq. millimeters = .155 sq. inch
 1 sq. decimeter = 100 sq. centimeters = 15.5 sq. inches
 1 sq. meter (centare) = 100 sq. decimeters = 10.76 sq. feet
 1 sq. dekameter (are) = 100 sq. meters = 1,076.4 sq. feet
 1 sq. hectometer (hectare) = 100 sq. dekameters = 2.47 acres
 1 sq. kilometer = 100 sq. hectometers = .386 sq. mile

Cubic Measure

1 cu. centimeter = 1000 cu. millimeters = .06 cu. inch
 1 cu. decimeter = 1000 cu. centimeters = 61.02 cu. inches
 1 cu. meter = 1000 cu. decimeters = 35.31 cu. feet

Approximate Conversion Factors

To change	To	Multiply by	To change	To	Multiply by
inches	centimeters	2.540	ounce-inches	newton-meters	.007062
feet	meters	.305	centimeters	inches	.394
yards	meters	.914	meters	feet	3.280
miles	kilometers	1.609	meters	yards	1.094
square inches	square centimeters	6.451	kilometers	miles	.621
square feet	square meters	.093	square centimeters	square inches	.155
square yards	square meters	.836	square meters	square feet	10.764
square miles	square kilometers	2.590	square meters	square yards	1.196
acres	square hectometers	.405	square kilometers	square miles	.386
cubic feet	cubic meters	.028	square hectometers	acres	2.471
cubic yards	cubic meters	.765	cubic meters	cubic feet	35.315
fluid ounces	milliliters	29.573	cubic meters	cubic yards	1.308
pints	liters	.473	cubic meters	fluid ounces	.034
quarts	liters	.946	milliliters	pints	2.113
gallons	liters	3.785	liters	quarts	1.057
ounces	grams	28.349	liters	gallons	.264
pounds	kilograms	.454	grams	ounces	.035
short tons	metric tons	.907	kilograms	pounds	2.205
pound-feet	newton-meters	1.356	metric tons	short tons	1.102
pound-inches	newton-meters	.11296			

Temperature (Exact)

°F	Fahrenheit temperature	5/9 (after subtracting 32)	Celsius temperature	°C
----	------------------------	----------------------------	---------------------	----

